

Your guide to safer boiler operation

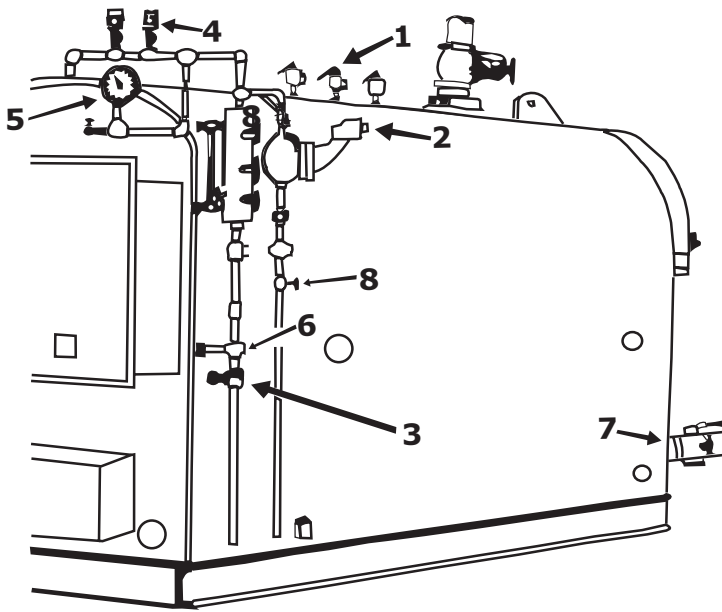

Steam boiler

1. Safety valve
2. Low-water cutoff
3. Water column blow-down valve
4. Pressuretrols (one is high-limit safety)
5. Steam pressure-gauge
6. Water column clean-out (cross tee)
7. Bottom blow-off and drain valve
8. Low-water cutoff/blow-off valve

Note: Second low-water-cutoff not shown in diagram

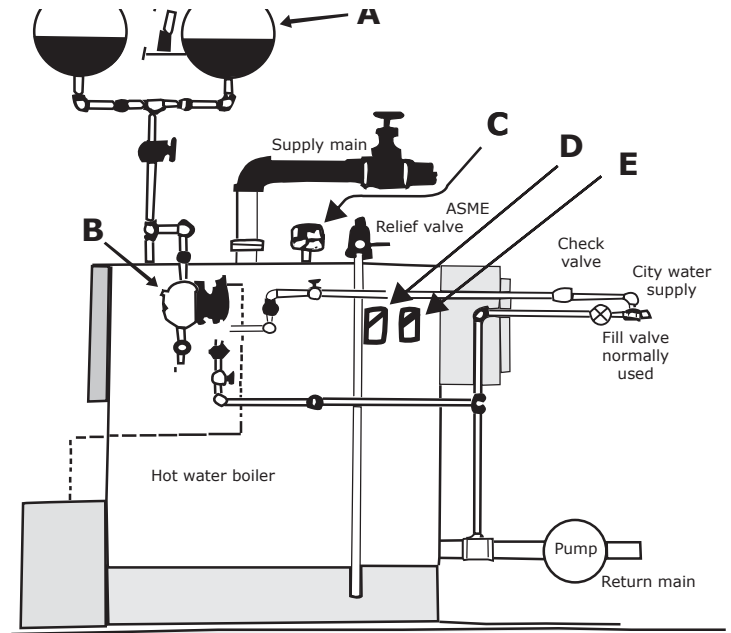

Hot-water boiler

- A. Expansion tank
- B. Low-water cutoff
- C. Combination temperature/pressure gauge or altitude/temperature gauge
- D. Operating aquastat
- E. High-limit safety aquastat

Boiler water-level – The first duty when taking over a boiler-room shift is to make certain the pipe, fittings and valves between the water glass and boiler are free and open by blowing down the water column and water glass and noting the promptness of the return of water to the glass.

The most important rule – The most important rule for the safe operation of boilers is to maintain the proper water-level at all times, and as constant a level as conditions will permit. If water is not visible in the water glass, shut the boiler off immediately until a safe water-level has been determined.

Low-water and feedwater controls – The low-water cutoff is the most important electrical/mechanical device on your boiler for maintaining a safe water-level. If a low-water condition develops, it could very well result in an overheating and explosion of your boiler. The low-water cutoff should be tested at least weekly.

Low-water cutoff, evaporation test (steam boiler) – While the boiler is in operation, shut off the feedwater pump and monitor the boiler water-level. The low-water cutoff should shut down the burner before the water level goes out of sight low; if the burner does not shut off, restart the feedwater pump before the water level goes out of sight low and immediately troubleshoot the low-water cutoff to determine the cause of failure. The boiler must be under constant attendance by a properly licensed engineer at all times during this test.

Low-water cutoff, slow drain test (steam boiler) – While the boiler is in operation, shut off the feedwater pump and slowly open the bottom blow valve to drain the water from the boiler. The low-water cutoff should shut down the burner before the water level goes out of sight low; if the burner does not shut off, restart the feedwater pump before the water level goes out of sight low and immediately troubleshoot the low-water cutoff to determine the cause of failure. The boiler must be under constant attendance by a properly licensed engineer at all times during this test.

Firing – Aside from the standpoint of economy, maintain the fire as uniformly as possible to avoid an excessive rate of combustion, undesirable variations in temperature and possible explosions. The destructive force in a boiler explosion is caused by the instant release of energy stored in the water as heat.

Water gauges – Keep all connections and valves clear. Test by blowing down the water glass and water column regularly. Gauge cocks or tri-cocks should also be blown regularly.

Safety valves – The safety valve is the most important valve on the boiler. Safety valves prevent dangerous over pressurization of the boiler. Safety valves are installed in case there is failure of pressure controls or other devices designed to control the firing rate. All safety valves should be kept free of debris by testing the safety valve regularly. This should be done when the steam pressure is at approximately 75 percent of the safety-valve set pressure. Safety and safety-relief valves on low-pressure boilers should be tested at least quarterly, this is in accordance with the National Board Inspection Code.

Blow-down valves – The concentration of solids in the boiler should be measured and the boiler blown-down at such intervals as necessary to maintain established limits. Blow-down valves are placed at the lowest point of the boiler for the purpose of blowing sediment or scale from the boiler. They should be maintained in good working order and are to be opened and closed carefully when used.

Starting fires in a boiler – Before starting fires in a cold boiler or restarting a fire that may have been accidentally extinguished, the entire fireside of the boiler must be thoroughly ventilated (purged) with the dampers open to remove unburned gases before attempting to relight the fire. Attempting to start a fire in a boiler with unburned gases is the most common cause of boiler furnace explosions.

Boiler-room requirement – A current proper engineer's license and log shall be posted in the boiler room. It is the responsibility of the owner and the engineer to make sure the boiler is inspected annually.

Hot-water systems – These systems are equipped with expansion tanks for the expansion and contraction of the water as the temperature varies.

Firing cycle, power burners – The burner will start when the aquastat or pressuretrol calls for heat. The breeching damper will open and the draft fan will purge the combustion chamber. The main gas or oil valve will be energized when the pilot or ignition is proved.

Repairs – Any excessive overheating or burning, and any major repairs, must be reported to your boiler inspector.

Classification of boilers – High-pressure boilers are boilers operating at a steam or other vapor pressure in excess of 15 psig, or a water or other liquid boiler in which the pressure exceeds 160 psig, or has a temperature greater than 250 degrees Fahrenheit. Others are low-pressure boilers.

License requirement – Minnesota Statutes §183.501 states "No person shall be entrusted with the operation of or operate any boiler, steam engine or turbine who has not received a license of proper grade covering that boiler, steam engine or turbine.

Study material – The Division of Boiler Inspection has no study material available and suggests you contact your nearest technical college for classes or resource materials, or contact a library or bookstore for the appropriate book.

The following books may prove useful to boiler operators:

- Special Engineer: *Safe Boiler Operation Fundamentals* by ATP and *Low Pressure Boilers* by Frederick M. Steingress
- Grade "C" licenses: *Low Pressure Boilers* by Frederick M. Steingress
- Grade "B" licenses: *High Pressure Boilers* by Frederick M. Steingress and H.J. Frost
- Grade "A" licenses: *Steam Plant Operation* by Woodruff and Lammers
- Grade "B" and "A" licenses: *Stationary Engineering* by Steingress, Frost and Walker

This document can be made available in alternative formats, such as large print, Braille or audio, by calling (651) 284-5031; TTY call 1-800-627-3529.