

INSTRUCTION GUIDE

For Set-Up & Installation
of Single-Section
& Double-Section
Manufactured Homes by...

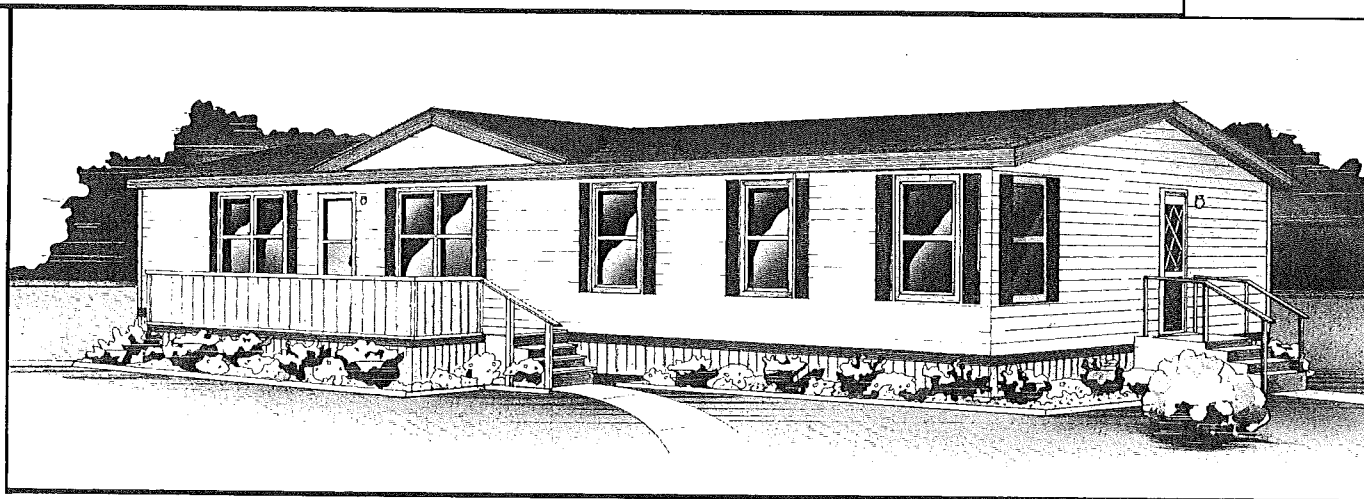

CHAMPION
HOME BUILDERS CO.

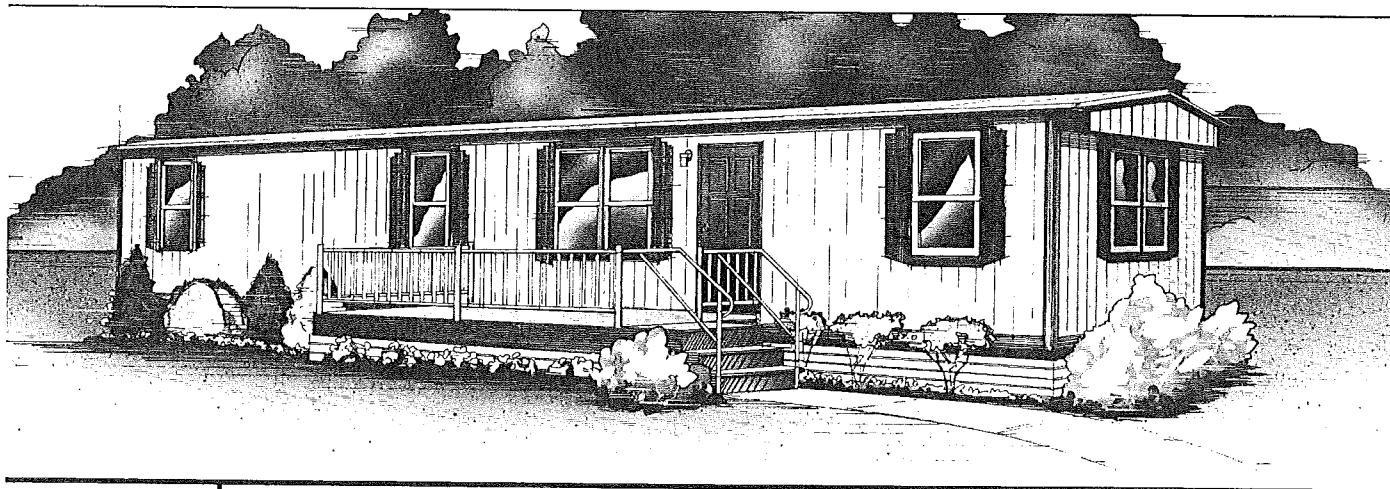

HOMEOWNERS: Only qualified persons should perform any set-up, installation, repairs, changes or alterations to any portion of your home.

TABLE OF CONTENTS

Introduction and Warning	3
Roof Load Zone Map & Wind Zone Map	4
General Information	5
Jacking & Blocking Procedure	5
Singlewide Set-up Procedure	6
Doublewide Set-up Procedure	6
Typical Singlewide Blocking	7,8
Typical Doublewide Blocking	9,10
Tie-Down Instructions	11,12
Doublewide Connection Details	13,14
Utility System Connections	15,16
Typical Water & Drain Connection	17
Typical Water & Gas Crossover	18
Typical Electrical Crossover	19
Alternate Electrical Crossover	19
Exterior Light Connection	20
Electrical Connection of Evaporative Cooler	20
Electrical Feeder Assembly	20,21
Typical Heat Duct Crossover	21
Dryer Exhaust System	22
Telephone Wiring	23
Paco Set-up	23
Products From Plants to Which This Guide Applies	Outside Back Cover

RADCO **FEDERAL MANUFACTURED
HOUSING CONSTRUCTION
& SAFETY STANDARDS**
 DEC 9 1987
3 **APPROVED**

WARNING These instructions apply directly to all involved in the set up of manufactured housing. The dealer, installer, set-up crew, home owner, and anyone else involved in home setup must realize that manufactured homes are large, heavy objects. Care must be exercised by all those involved to assure the physical safety of those working around, in, or under the home during set up.

Adequate attention must be given to the strategic placement of safety timbers or other safety blocking materials, as well as their supports, beneath the home to prevent the home from falling or moving in such a way that it could injure someone during set up or disassembly procedures.

Safety supports should be positioned beneath solid members such as I-beam and floor joists and NEVER under a member like an axle attached to move or compress.

Never allow men to work under the home while it is moving unless blocking is in place which will safely transfer the weight of the home from the moving support jacks to fixed safety blocking without endangering human life.

THIS FIXED SAFETY BLOCKING IS EXTREMELY IMPORTANT IF A MAJOR PORTION OF THE HOME MUST BE RAISED A SUBSTANTIAL HEIGHT TO COMPENSATE FOR LOCAL TERRAIN.

INTRODUCTION

This home has been designed, constructed and inspected in accordance with the Federal Manufactured Housing Construction and Safety Standards in effect on the date of manufacture.

The design criteria for this home may be found on the data plate, which also contains other essential information such as where this home was manufactured, factory-installed equipment, and heating and cooling information. This data plate may be found attached to the home in one of the following locations:

1. Rear Bedroom Closet Wall
2. Laundry Area
3. Water Heater Door
4. Near Main Electric Panel

Please crosscheck the data plate supplied with your home with the roof load and wind zone maps shown on page 4 to assure that your home is located properly. These maps indicate the acceptable areas of the United States where your home may be safely located.

In preparing this home for occupancy, IT IS EXTREMELY IMPORTANT THAT IT BE PROPERLY SET, BLOCKED AND LEVELED WITHIN REASONABLE TOLERANCES by a knowledgeable and experienced manufactured home dealer or installer.

Proper set up will, under normal circumstances, prevent the home from sagging and prevent expensive repair bills.

The following information is presented to instruct and assist qualified personnel in setting up this home. Also refer to the Manufactured Home Owner's Maintenance Guide for additional information.

Equipment/appliances not installed by the manufacturer must be installed by qualified personnel following the installation instructions supplied with the equipment/appliances. Champion cannot accept responsibility for damage caused by equipment/appliances improperly installed, or unsuitable for use in manufactured housing (i.e. equipment/appliances not listed for use in manufactured housing) installed by others.

GENERAL INFORMATION

SITE PREPARATION

The home site must be properly graded and sloped to provide storm drainage runoff and to prevent water accumulation.

A vapor barrier, such as a layer of polyethylene plastic sheeting or roofing felt must be placed on the ground under the home.

FIRM FOUNDATION

A firm foundation is absolutely necessary before the home is blocked and leveled.

This should prevent the home from sagging and will be considered before Champion Home Builders Co. honors any sag-related warranty claims.

If the site is on filled-in soil, it must be compacted to at least 90% of its maximum relative density. If you are unsure of soil bearing capacity, confer with local building authority for the recommended soil bearing capacity in your location. Footings should then be supplied to comply with these recommendations.

Before the home is blocked and leveled, it should be set on a solid poured concrete slab or "pad," wide ribbons of poured concrete, or concrete pier footings, whichever foundation is suggested and judged best by the home installer as required by local regulation.

PROPER BLOCKING SUPPORTS

The blocking supports for the home should be sturdy. Adjustable steel jacks especially designed for home blocking and leveling are highly popular and recommended. However, cement blocks may be adequate blocking devices. Unreinforced hollow block shall not be higher than 4 times its least dimension.

POSSIBLE CONSEQUENCES OF INCORRECT BLOCKING AND LEVELING

Incorrect setting, blocking and leveling of the home can produce a sagging home and these possible related conditions:

- (1) Buckling and/or loosening of walls, partitions, siding, ceilings, doors, floors, linoleum, carpeting, insulation, wiring, sinks, tubs, toilets, weather stripping and miscellaneous fixed original fixtures of the home.
- (2) Leaking windows, doors, roof, ceiling, walls, floor, seams and joints in general caused from rain, snow or moisture.
- (3) Improper closing, binding and sagging of windows, cabinets and inside and outside doors.
- (4) Malfunctioning of plumbing, water outlets, lighting fixtures, electrical heating and air conditioning system.

PERIODIC RELEVELING OF HOME MAY BE NECESSARY

If any of the aforementioned sag-related conditions occur, as listed in conditions numbered (1), (2), (3) and (4) after the home has been properly blocked and leveled, you should recheck the home's leveling. In some parts, or regions of the country, initial proper blocking and leveling of the home can be gradually impaired due to generally abnormal or even relatively normal settling of the land or site on which it sits. Future transportability of the home may be impossible if structural damage has been introduced through improper blocking or neglect of periodic inspection of the home's blocked and leveled condition.

To check whether the home needs possible releveling from time to time, simply place a carpenter's level upon the floor of the home at several and various lengthwise and crosswise spots in each room to see if it is reasonably level throughout.

Should releveling be necessary, corrective measures can be taken by having a competent and knowledgeable home mover or installer follow the suggested procedures outlined on Page 6. Although these procedures may appear easy for an amateur to attempt, they require repeated experience to master.

Before releveling, loosen frame tie downs and optional ground straps prior to jacking up home.

SINGLEWIDE AND DOUBLEWIDE JACKING AND BLOCKING PROCEDURES

General:

1. Use only jacks in good condition with a 12-ton minimum rating.
2. To distribute the concentrated loads created by the jacks, 3/8" x 4" x 12" steel plates or 4" x 4" x 12" hardwood blocks should be placed between the jacks and the main beam.
3. Caution: To prevent the jacks from tipping, be sure that there is a firm support under the jack base.
4. For safety's sake, tires and axles should be left on the unit until all the blocking is done.
5. You must follow the sequence of jacking outlined on the following pages to avoid overstressing structural members. Excessive or nonuniform jacking during the leveling process could cause the home to be racked or twisted, thus voiding your warranty.
6. It is recommended that the home be set as low to the ground as possible. However, exterior finishes should be no closer than 8" from the ground.

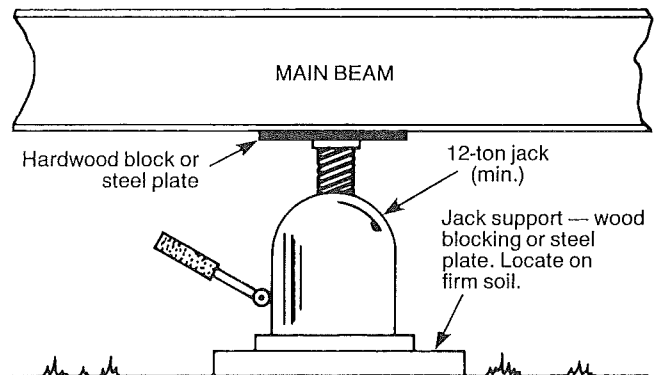

SINGLEWIDE SET-UP PROCEDURE

General:

1. Position the home in its final location.
2. Position support piers (i.e. concrete blocks with hardwood shims, adjustable metal supports, etc.) under the main I-beams and at exterior door openings as shown on pages 7 and 8.
3. Rough level the home. If the hitch jack is used in this process, place adequate blocking under the home to prevent it from falling and hurting someone, should the screw jack fail. If it is necessary to move the home more than a few degrees to attain a "rough level" condition, then use heavy-duty jacks with proper support under them.
4. Finish leveling the home. Where possible, operate the 12-ton jacks used in this step from outside the perimeter of the home. Use long handles and avoid working under the home. Use a water level in conjunction with a carpenter's level or similar equipment for this step. The last height adjustment is made by jacking up the main beam and inserting hard wood shims between the main beams and piers or adjusting the adjustable steel jacks.
5. The tie-down system must be connected as shown on Page 11. UNDER NO CIRCUMSTANCES ARE THE OPTIONAL GROUND STRAPS TO BE USED WITHOUT THE FRAME TIE DOWNS.
6. Connect and test the utility systems (electrical, water, drain lines and gas lines as applicable) as detailed in the utility section.
7. Check the home for the following:
 - (A) Exterior Doors (should open and close easily, lock and unlock easily).
 - (B) Passage Doors (should open and close easily and be in proper alignment).
 - (C) Windows (should open and close easily).
NOTE: READ EGRESS INSTRUCTIONS ON ALL BEDROOM WINDOWS.
 - (D) Cabinet doors and drawers (should open and close easily and be in proper alignment).
8. If it becomes necessary to relevel the home, loosen the frame tie downs and optional ground straps and follow the procedures in Step #4.

DOUBLEWIDE SET-UP PROCEDURE

General:

1. Position the first section of the home in its final location.
2. Rough and finish level this section, using steps 2 through 4 of the single-wide set-up procedures. Use pier spacing shown on pages 9 and 10 under main beams, exterior doors, and marriage wall openings larger than 4 feet.
3. Remove shipping material from both units and check for obstructions that would prevent proper mating of the two units. Leave shipping wall framing in place until both units are together and the roof, floor and wall connections have been made.
4. In order to provide a seal between the sections of the home (which will reduce air currents and related problems), attach a strip of insulation (4" or larger in width) along the vertical end wall, interior wall, horizontal roof ridge rail and floor rim rail mating surfaces. This insulation will be compressed to form a seal as the sections of the home move together. Check for voids in this seal after the sections are together and pack any remaining voids located with insulation. Note: Other resilient materials may be used to form the seal.
5. Position the second section along side of the first and as near to it as possible. Check for alignment of walls between the sections. If any adjustments are necessary, make them now.
6. Move the second section into contact with the first section and level as described in step 2.
7. Fasten roof ridge beam together and seal as shown on Page 13. If the home has a shingle roof, remove the shipping strips and seal the holes.
8. Fasten the floor joists together as shown on page 13 — seal any penetrations of the floor cavity.
9. Remove shipping walls after fastening marriage wall openings together as shown on Page 13.
10. Connect and test utility systems (electrical, water, drain lines, if applicable) as detailed in Utility Section.
11. See Page 21 for heat duct crossover connection.
12. The tie-down systems must be connected as shown on Page 11. UNDER NO CIRCUMSTANCES ARE THE OPTIONAL GROUND STRAPS TO BE USED WITHOUT THE FRAME TIE DOWNS.
13. Trim out archways, install ceiling beams, passage doors, etc. See page 13.

TYPICAL BLOCKING DIAGRAM FOR 12' & 14' SINGLEWIDES

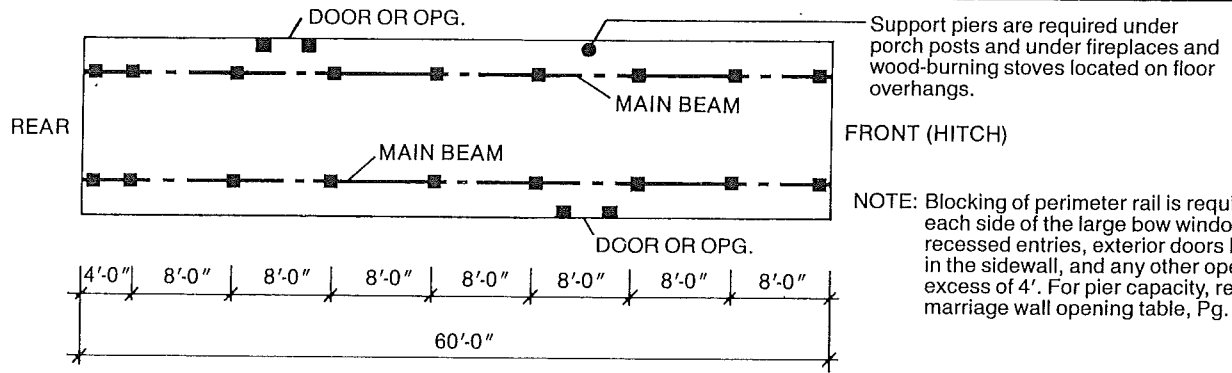

NOTE: Blocking of perimeter rail is required at each side of the large bow windows, recessed entries, exterior doors located in the sidewall, and any other opening in excess of 4'. For pier capacity, refer to marriage wall opening table, Pg. 9.

MINIMUM PIER CAPACITIES (in lbs.)

MINIMUM SPACING FOR BLOCKING	ROOF LOAD ZONE		
	20#	30#	40#
12' wide 8'0" o.c. max.	3750	4225	4700
14' wide 8'0" o.c. max.	4328	4880	5424

The diagram above shows the minimum required placement of blocks under the frame of a typical length and width home. It is extremely important to check with local building officials prior to blocking your home as to the latest local codes in your area.

FRAME BLOCKING

Begin by placing piers at front and rear of home. Starting at front, place piers at a maximum of 8' o.c. along both main beams the entire length of home. Follow this procedure for any length of Champion-built home.

FRAME BLOCKING PIER FOOTINGS

Based on a soil capacity of 1000 lb. per square foot, a suggested footing size for all piers is 2'6" square.

Alternate methods are acceptable if they meet with local soil bearing capacities.

FOR 60# ROOF LOAD ZONE SEE BELOW.

TYPICAL BLOCKING DIAGRAM FOR 12' & 14' SINGLEWIDES— 60 LB. ROOF LOAD

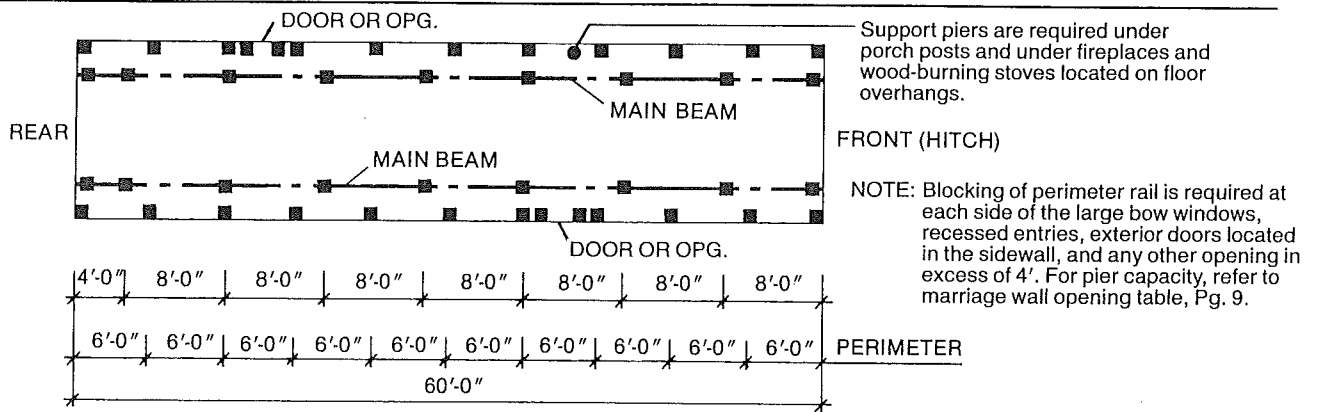

NOTE: Blocking of perimeter rail is required at each side of the large bow windows, recessed entries, exterior doors located in the sidewall, and any other opening in excess of 4'. For pier capacity, refer to marriage wall opening table, Pg. 9.

MINIMUM PIER CAPACITIES (in lbs.)

MINIMUM SPACING FOR BLOCKING	ROOF LOAD ZONE 60#	MINIMUM SPACING FOR PERIMETER BLOCKING	ROOF LOAD ZONE 60#
12' wide 8'0" o.c. max.	2272	12' wide 6'0" o.c. max.	2510
14' wide 8'0" o.c. max.	2648	14' wide 6'0" o.c. max.	2916

NOTE: 60-lb. roof load areas require BOTH frame and perimeter blocking

The diagram above shows the minimum required placement of blocks under the frame of a typical length and width home. It is extremely important to check with local building officials prior to blocking your home as to the latest local codes in your area.

FRAME BLOCKING

Begin by placing piers at front and rear of home. Starting at front, place piers at a maximum of 8' o.c. along both main beams the entire length of home. Follow this procedure for any length of Champion-built home.

PERIMETER BLOCKING

Begin by placing piers at front and rear of home. Starting

at front, place piers at a maximum of 6' o.c. along both rim members the entire length of home. Follow this procedure for any length of Champion-built home.

FRAME BLOCKING PIER FOOTINGS

Based on a soil capacity of 1000 lb. per square foot, a suggested footing size for all piers is 2'6" square.

PERIMETER BLOCKING PIER FOOTINGS

Based on a soil capacity of 1000 lb. per square foot, a suggested footing size for all piers is 2'0" square.

Alternate methods are acceptable if they meet with local soil bearing capacities.

TYPICAL BLOCKING DIAGRAM FOR 16' SINGLEWIDES

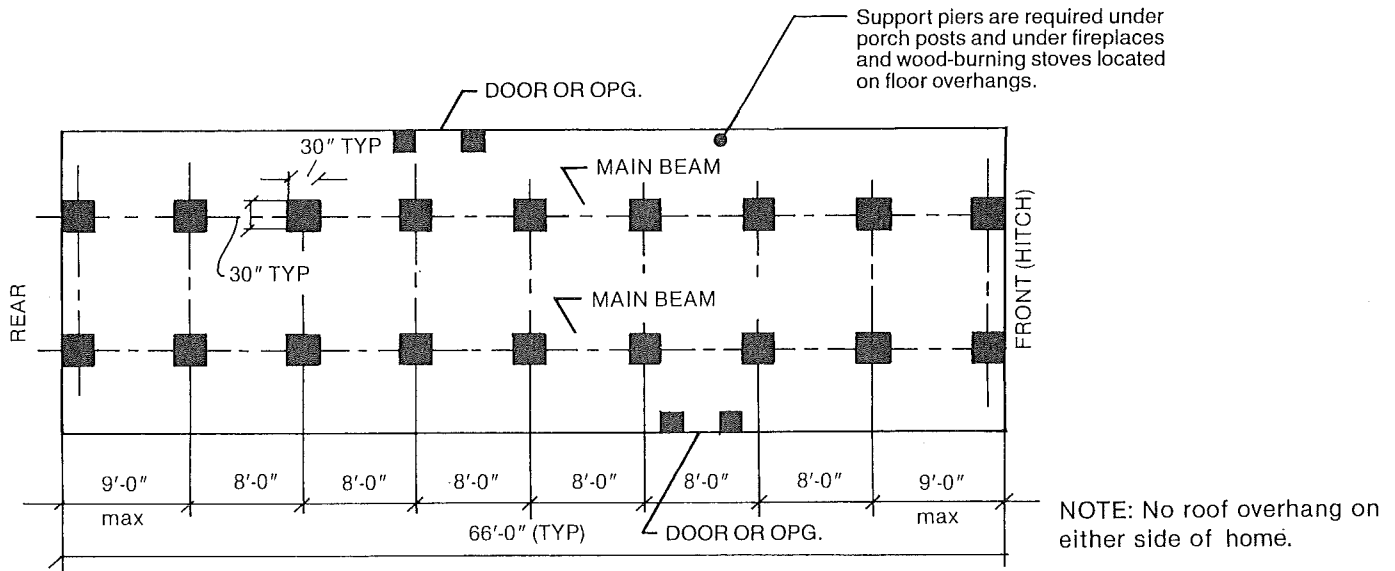

The diagram above shows the minimum required placement of blocks under the frame of a typical length and width home. It is extremely important to check with local building officials prior to blocking your home as to the latest local codes in your area.

FRAME BLOCKING

Begin by placing piers at front and rear of home. Starting at front, place piers at a maximum of 8' o.c. along both main

beams the entire length of home. Follow this procedure for any length of Champion-built home.

FRAME BLOCKING PIER FOOTINGS

Based on a soil capacity of 1000 lb. per square foot, a suggested footing size for all piers is 2'6" square.

Alternate methods are acceptable if they meet with local soil bearing capacities.

NOTE: Blocking of perimeter rail is required at each side of the large bow windows, recessed entries, exterior doors located in the sidewall, and any other opening in excess of 4'. For pier capacity, refer to marriage wall opening table, Pg. 9.

MINIMUM PIER CAPACITY (in lbs.)

MINIMUM SPACING FOR BLOCKING	ROOF LOAD ZONE	
	20#	30#
16' wide 8'0" o.c. max.	4860	5500

TYPICAL BLOCKING DIAGRAM FOR DOUBLEWIDES

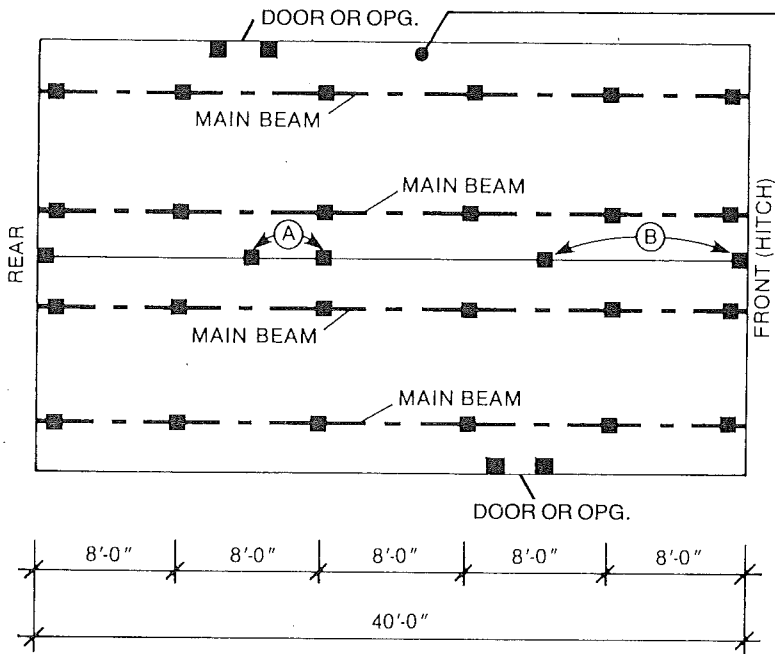

Support piers are required under porch posts and under fireplaces and wood-burning stoves located on floor overhangs.

FRAME BLOCKING PIER FOOTINGS

Based on a soil capacity of 1000 lb. per square foot, a suggested footing size for all piers is 2'6" square.

Alternate methods are acceptable if they meet with local soil bearing capacities.

It is extremely important to check with local building officials as to the latest local codes in your area.

NOTE: Blocking of perimeter rail is required at each side of the large bow windows, recessed entries, exterior doors located in the sidewall, and any other opening in excess of 4'. For pier capacity, refer to marriage wall opening table, below.

MINIMUM PIER CAPACITIES (in lbs.)

MINIMUM SPACING FOR BLOCKING	ROOF LOAD ZONE		
	20#	30#	40#
24' wide 8'0" o.c. max.	3750	4225	4700
28' wide 8'0" o.c. max.	4328	4880	5424
32' wide 8'0" o.c. max.	4860		

The diagram above shows the minimum required placement of blocks under the frame of a typical length and width home.

FRAME BLOCKING

Begin by placing piers at front and rear of home. Starting at front, place piers at a maximum of 8' o.c. along both main beams the entire length of home. Follow this procedure for any length of Champion-built home.

Other blocking positions are also required under the center marriage walls, depending on the model. These positions are determined by the locations of the openings in the marriage wall. There must be blocking at each end of the openings shown as A and B on diagram above and vary depending on the model. For clear span openings and pier capacities see the chart shown above.

FOR 60# ROOF LOAD ZONE SEE PAGE 10

MINIMUM PIER CAPACITIES FOR MARRIAGE WALL OPENINGS (in lbs.)

CLEAR SPAN DISTANCE IN MARRIAGE WALL	20#		30#		40#		
	24'	28'	32'	28'	24'	28'	
4'-1" — 8'-0"	1260	1476	1692	1724	2020	2192	2568
8'-1" — 12'-0"	1890	2214	2539	2586	3030	3288	3852
12'-1" — 16'-0"	2520	2952	3385	3448	4040	4384	5136
16'-1" — 20'-0"	3150	3690	4230	4320	5060	4485	6425

NOTE: For 26' wide homes, use marriage wall pier capacities for 28' wide homes.

TYPICAL BLOCKING DIAGRAM FOR DOUBLEWIDES— 60 LB. ROOF LOAD

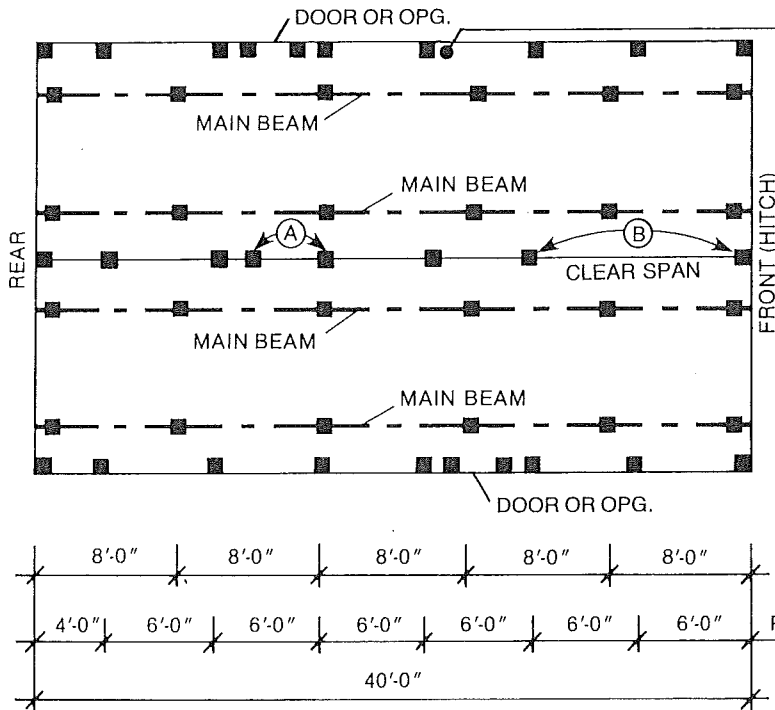

Support piers are required under porch posts and under fireplaces and wood-burning stoves located on floor overhangs.

FRAME BLOCKING PIER FOOTINGS

Based on a soil capacity of 1000 lb. per square foot, a suggested footing size for all piers is 2'6" square.

PERIMETER BLOCKING PIER FOOTINGS

Based on a soil capacity of 1000 lb. per square foot, a suggested footing size for all piers is 2'0" square.

Alternate methods are acceptable if they meet with local soil bearing capacities.

It is extremely important to check with local building officials as to the latest local codes in your area.

NOTE: 60-lb. roof load areas require BOTH frame and perimeter blocking. Pier capacities for perimeter blocking under marriage walls are twice the values shown in table.

NOTE: Blocking of perimeter rail is required at each side of the large bow windows, recessed entries, exterior doors located in the sidewall, and any other opening in excess of 4'. For pier capacity, refer to marriage wall opening table, below.

MINIMUM PIER CAPACITIES (in lbs.)

MINIMUM SPACING FOR BLOCKING	ROOF LOAD ZONE 60#	MINIMUM SPACING FOR PERIMETER BLOCKING	ROOF LOAD ZONE 60#
24' wide 8'0" o.c. max.	2272	12' wide 6'0" o.c. max.	2510
28' wide 8'0" o.c. max.	2648	14' wide 6'0" o.c. max.	2916

MINIMUM PIER CAPACITIES FOR MARRIAGE WALL OPENINGS (in lbs.)

CLEAR SPAN DISTANCE IN MARRIAGE WALL	60#	
	24'	28'
0'-4'-0"	1562	1830
4'-1"-8'-0"	3124	3660
8'-1"-12'-0"	4686	5490
12'-1"-16'-0"	6248	7320
16'-1"-20'-0"	7820	9160

NOTE: For 26' wide homes, use marriage wall pier capacities for 28' wide homes.

The diagram above shows the minimum required placement of blocks under the frame of a typical length and width home. It is extremely important to check with local building officials prior to blocking your home as to the latest local codes in your area.

OFFSET DESIGN SET-UP

Double section homes having the floors offset from each other shall be tied down as a single-section home for that portion of the floor which extends past the other. Blocking shall be placed at the inside corners where the floor joins, having a capacity of piers called for on marriage wall openings, with the span being the amount of projection.

FRAME BLOCKING

Begin by placing piers at front and rear of home. Starting at front, place piers at a maximum of 8' o.c. along both main beams the entire length of home. Follow this procedure for any length of Champion-built home.

Other blocking positions are also required under the center marriage walls, depending on the model. These positions are determined by the locations of the openings in the marriage wall. There must be blocking at each end of the openings shown as A and B on diagram above and vary depending on the model. For clear span openings and pier capacities see the chart shown above.

PERIMETER BLOCKING

Begin by placing piers at front and rear of home. Starting at front, place piers at a maximum of 6' o.c. along both rim members the entire length of home. Follow this procedure for any length of Champion-built home. Also add piers under the marriage walls. Clear span areas do not require marriage wall perimeter blocking.

TIE-DOWN INSTRUCTIONS FOR SINGLEWIDES

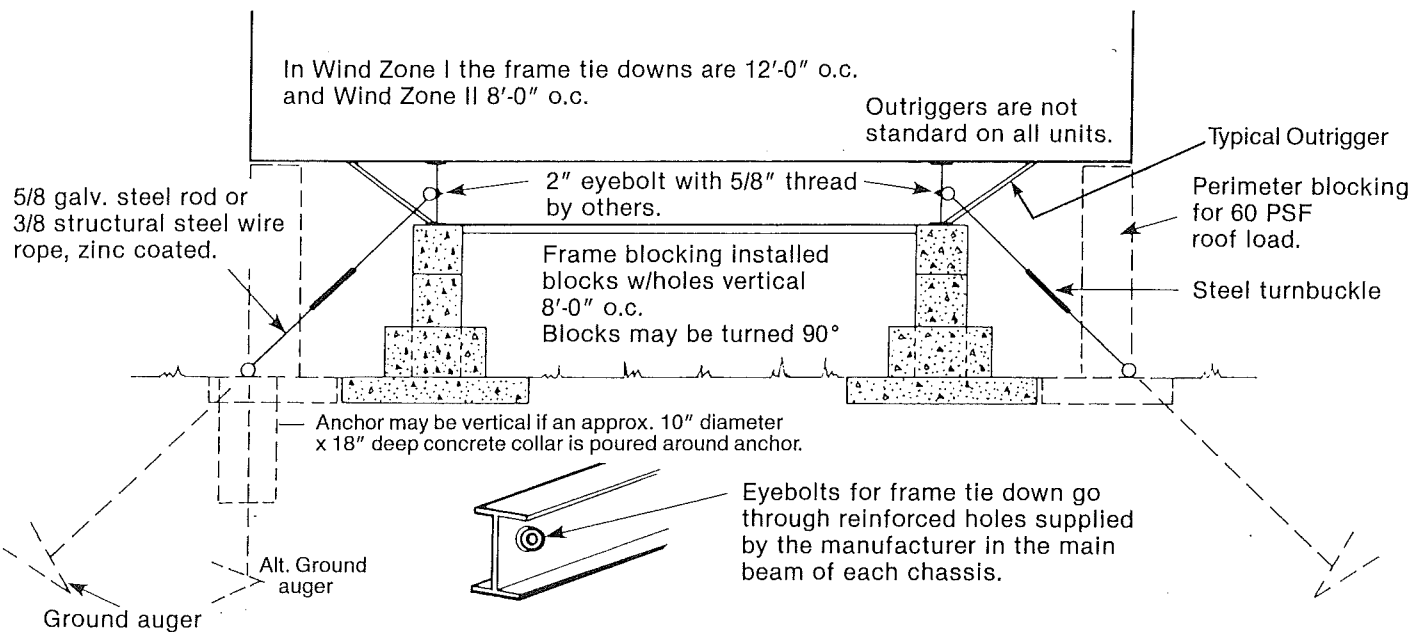

NOTE: Ground auger must be installed in such a way to resist lateral load.

All anchoring parts must be certified to 4725# capacity.

TIE-DOWN INSTRUCTIONS FOR DOUBLEWIDES

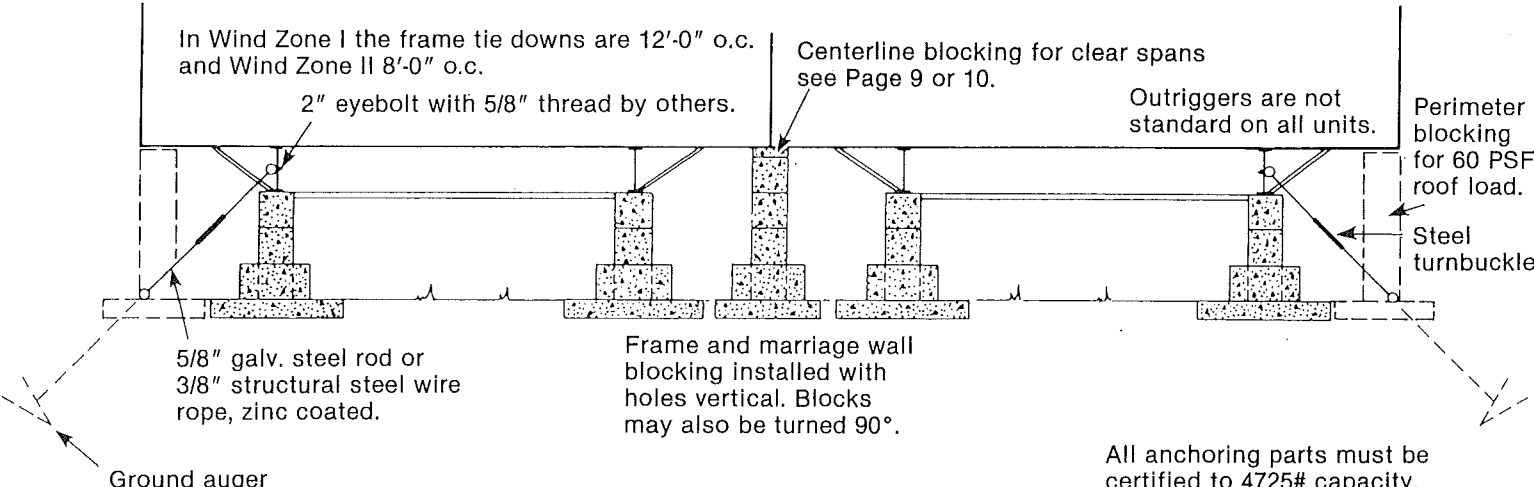

NOTE: Ground auger must be installed in such a way to resist lateral load.

All anchoring parts must be certified to 4725# capacity.

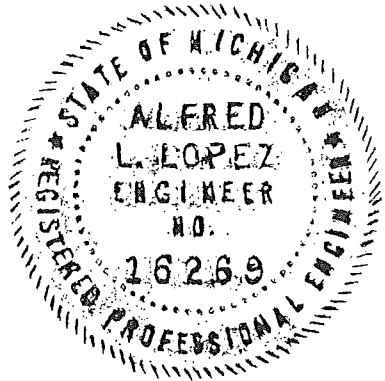

NOTE: Champion Home Builders has designed their homes to only require the use of frame ties. When optional ground straps are sold, their use is over and above that required by Champion and the Federal Standard for tie-down of our homes. Ground straps do not alter the requirements for frame ties. Under no circumstances are the optional ground straps to be used without frame ties. Unless the anchor is certified to accept the combined loads, optional ground straps must be fastened to separate ground anchors.

ALTERNATE TIE-DOWN INSTRUCTIONS FOR SINGLEWIDES AND DOUBLEWIDES

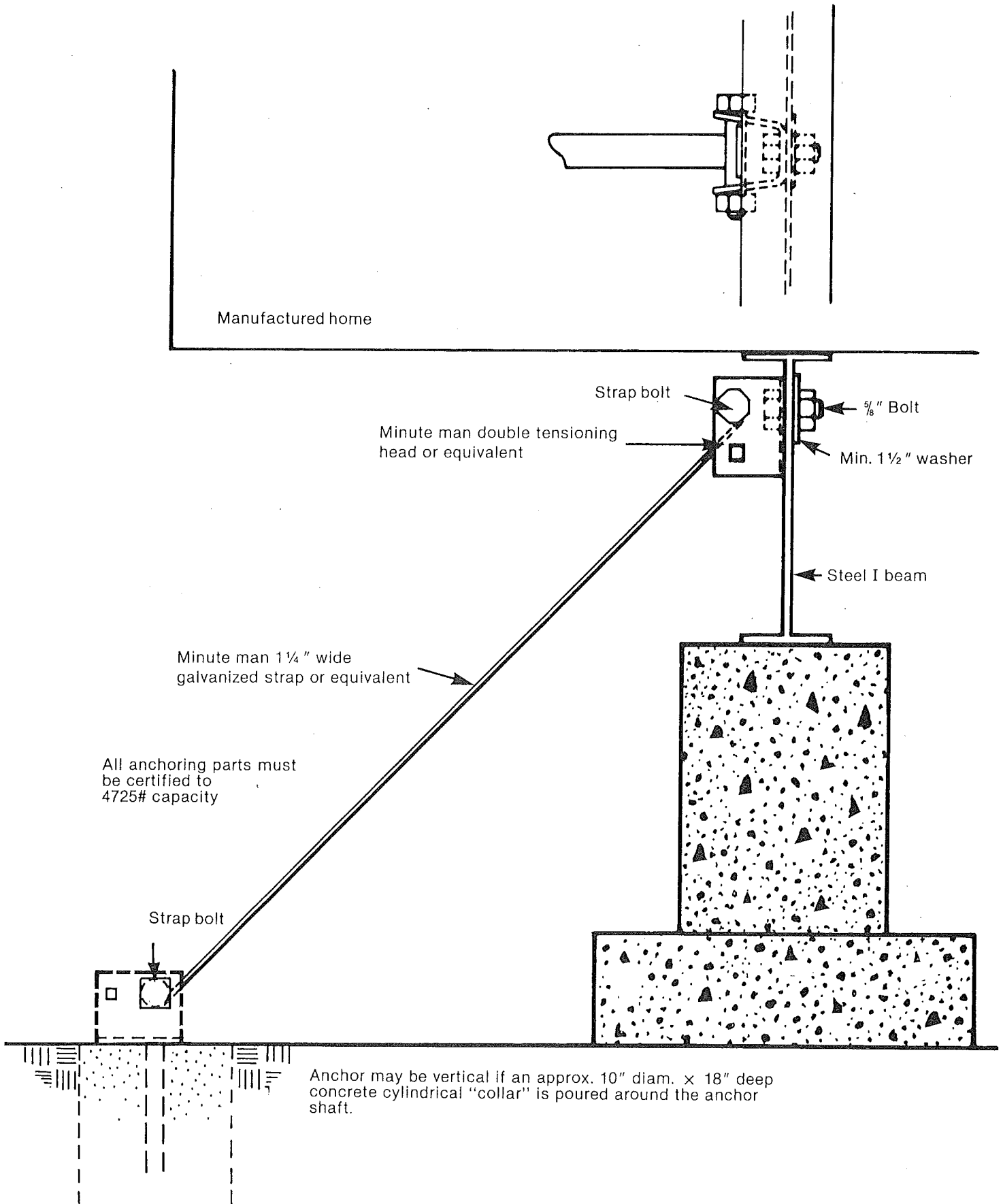

DOUBLEWIDE CONNECTION DETAILS

SHINGLE ROOF

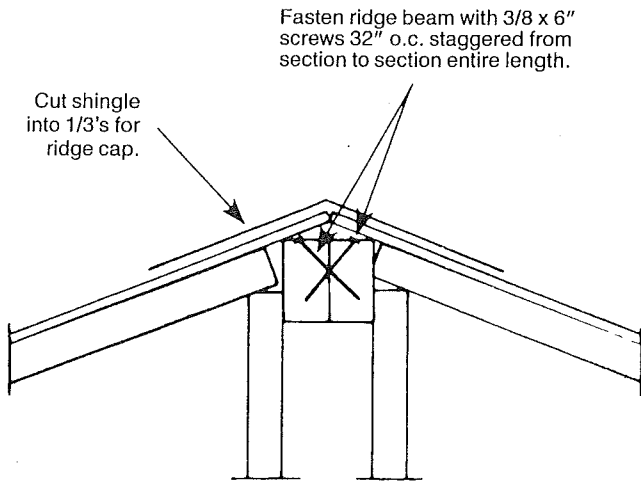

METAL ROOF

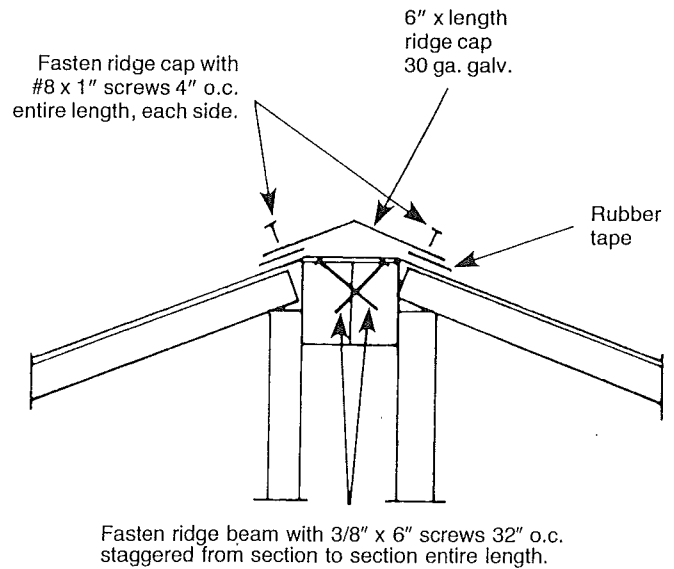

MARRIAGE WALL OPENINGS & RIDGE BEAMS IN CATHEDRAL CEILINGS

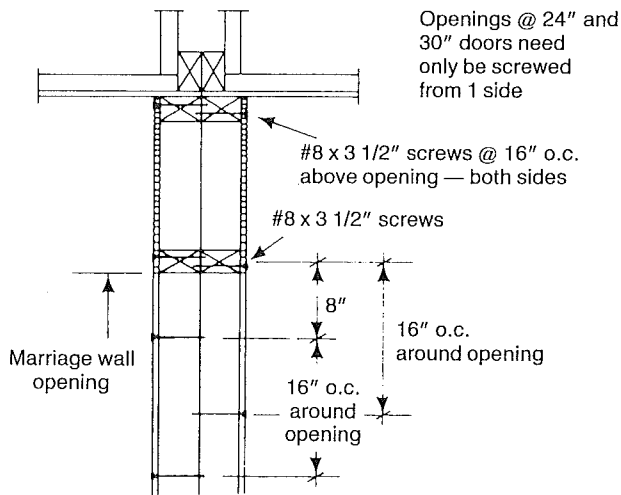

CEILING

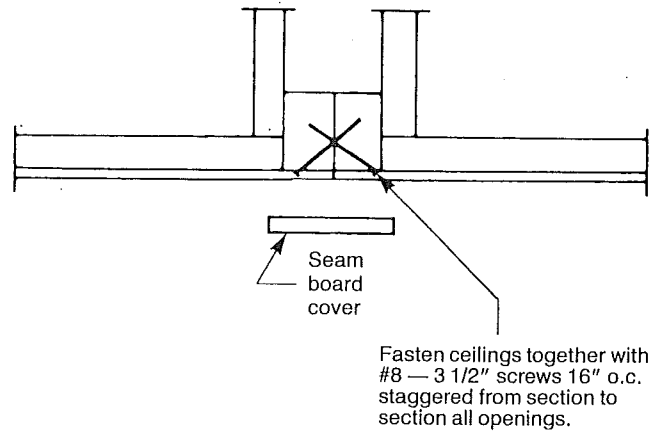

FLOOR

Aluminum threshold strip at openings not carpeted. Fasten with #3 — 3/4" drive nails through prepunched holes.

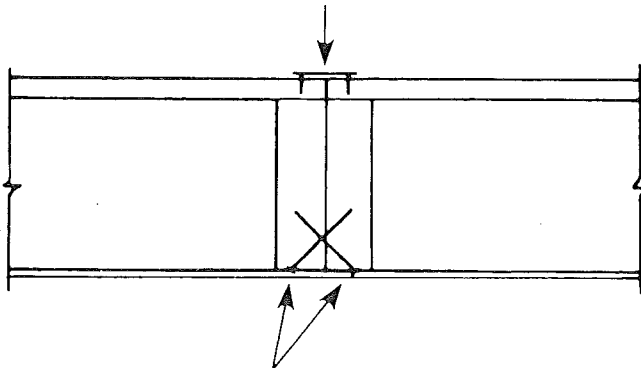

Fasten floor with 3/8 x 6" screws 32" o.c. staggered from section to section entire length.

INSTALLATION OF ELECTRICAL BOX FOR OPTIONAL FAN OR LIGHT

Install electrical box using fasteners provided and trim out as shown.

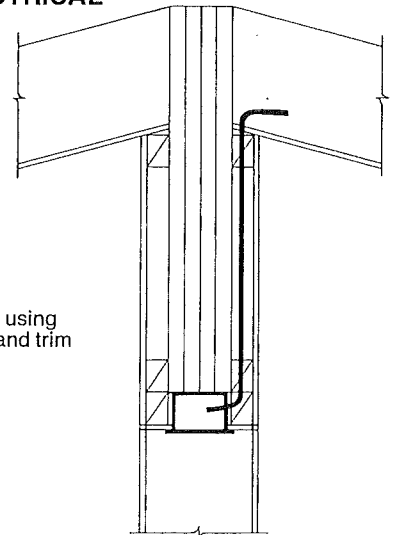

ALTERNATE FIELD APPLIED INTERIOR END WALL PANEL

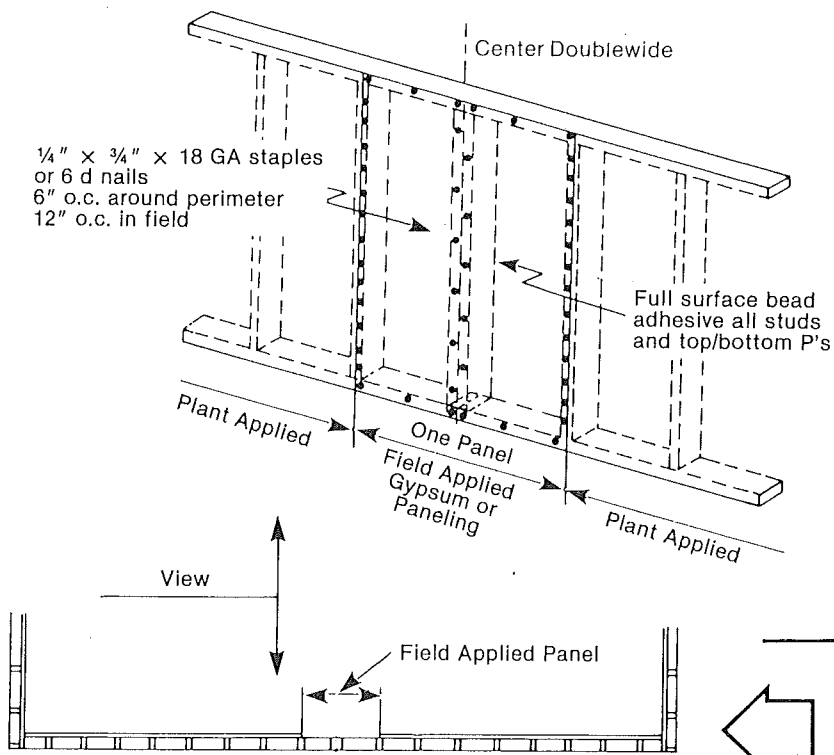

FIELD APPLIED WOOD SIDING AT END WALLS

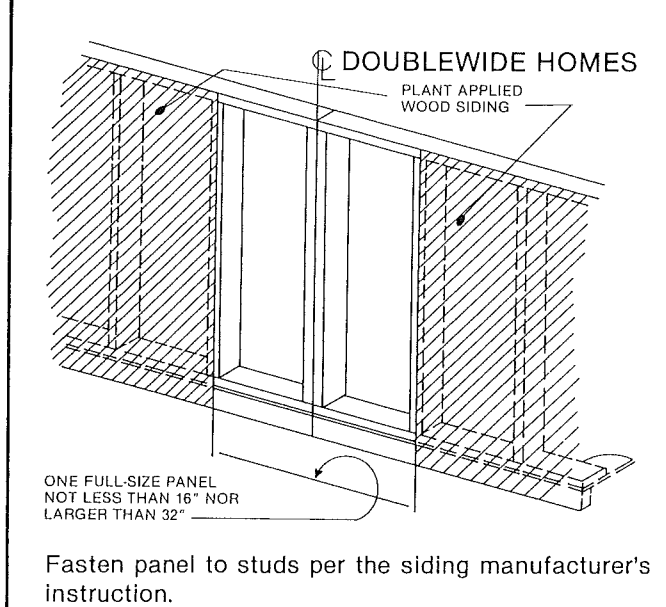

This detail approves the use of one panel to trim off the area on an end wall of a doublewide home with one panel.

This panel may not be smaller than 16" nor larger than 32" plus any additional width necessary to span gaps that may result when the 2 halves of the unit have been brought together.

HORIZONTAL LAP SIDING

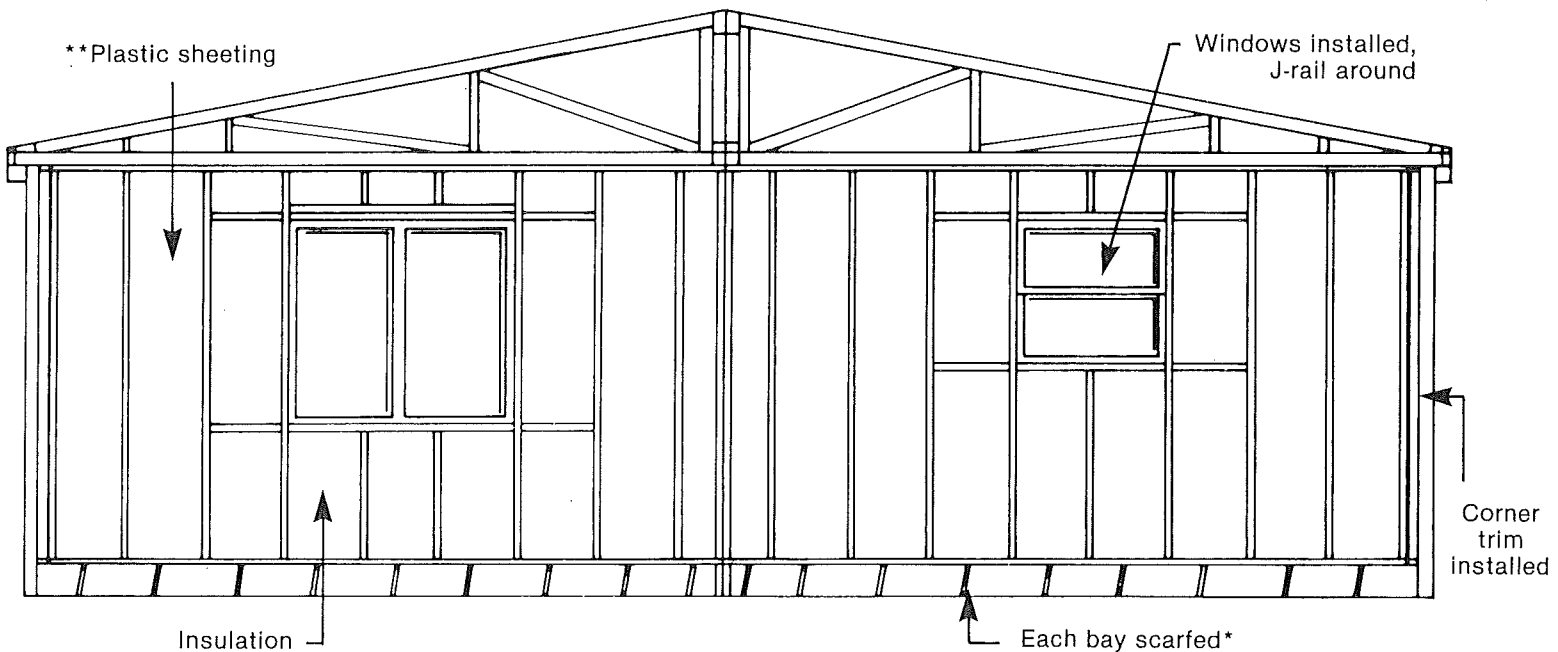

NOTE: Doublewide homes with horizontal lap siding may be shipped with no siding on the front and rear endwalls.

Champion will install: windows/doors trimmed with J-rail to receive siding; corner* trim for siding; insulation; and any optional sheathing. Front and rear will be covered with plastic sheathing for transit. All siding, starter, trim, fasteners, shutters, and vents will be shipped loose in home.

Dealer will complete installation after home is set up. This would include installation of roof vents if required. Siding to be installed per the siding manufacturer's instructions.

*Scarffing not required with optional sheathing.

**Plastic sheathing must be slit at top of each stud bay when no sheathing is used. With sheathing, the plastic sheathing must be removed.

UTILITY SYSTEM CONNECTIONS AND TESTING

GENERAL

Before leaving the factory, the gas, water, and drain line systems of this home have been tested for leaks. In addition, the electrical system has been thoroughly tested. However, prior to connecting these systems to their supply, another test is recommended to ensure that these systems are functioning properly after this home has been set up. On a multiwidth unit all connections between units should be made and visually inspected.

All utility connections must be made by authorized service personnel who are familiar with the requirements in the local area.

WATER DISTRIBUTION CONNECTION AND TEST

NOTE: THE WATER SYSTEM IN THIS HOME IS DESIGNED FOR WATER PRESSURE NOT TO EXCEED 80 PSI. IF THE WATER PRESSURE FROM THE SUPPLY SOURCE EXCEEDS, OR MAY EXCEED, 80 PSI, A PRESSURE-REDUCING VALVE MUST BE INSTALLED.

Connect the water supply to the home water inlet. Check the water distribution system and the supply connections for evidence of leakage. If this home is not equipped with a master water shutoff valve, one must be installed between the home and the supply source. This valve must be either a full port gate or full port ball valve with threaded or solder joints.

NOTE: IN AREAS SUBJECT TO FREEZING, THE EXPOSED WATER PIPE MUST BE PROTECTED. AN ELECTRICAL RECEPTACLE IS PROVIDED CONVENIENT TO THE POINT OF CONNECTION. TO PREVENT FREEZING, WRAP THE EXPOSED PIPE WITH HEAT TAPE LISTED FOR USE WITH A MANUFACTURED HOME. HEAT TAPE MUST BE INSTALLED IN ACCORDANCE WITH MANUFACTURER'S INSTRUCTIONS.

IF THIS HOME IS EQUIPPED WITH AN UNINSULATED WATER HEATER DOOR, THE PIPES IN THE WATER HEATER COMPARTMENT SHOULD BE INSULATED.

DRAINAGE SYSTEM TEST

1. Using drainline components shipped with the home, assemble materials under the home in their correct relationship to assure that all pipe and fittings are available to complete the installation.
2. Starting from the most remote end of the home assemble the pipe using proper solvent welding techniques. Support the line 4' - 0" on center assuring that at least 1/4" per foot of slope is achieved.

Connect the drainage piping system to the lot or site inlet and test by allowing water to flow into all fixtures. Check for any evidence of leakage in the drainage piping system as you empty each fixture.

DRAINING WATER LINES

If it becomes necessary to drain the water line to prevent freezing, first shut off the incoming water. Open all taps in the home, then disconnect the main shut-off valve under the home and allow water to drain out. After all the water has drained out, apply air until all water has been blown out.

The water heater may have a separate drain cock and must be drained with a short garden hose. Make sure power supply has been shut off prior to draining.

GAS PIPING SYSTEM TEST

CAUTION: THE GAS PIPING SYSTEM IN THIS MANUFACTURED HOME IS DESIGNED FOR A PRESSURE NOT TO EXCEED A 14-INCH WATER COLUMN (1/2 PSI). IF GAS FROM SUPPLY SOURCE EXCEEDS, OR MAY EXCEED, THIS PRESSURE, A PRESSURE REDUCING VALVE MUST BE INSTALLED. **CHECK ALL APPLIANCE CONNECTIONS AND THE GAS INLET CONNECTION FOR LEAKS WITH SOAPY WATER OR BUBBLE SOLUTION.**

CAUTION: DO NOT OVER PRESSURE GAS PIPING SYSTEM AS DAMAGE MAY RESULT.

For safe and efficient operation of gas appliances, the design pressure limitations should not be exceeded. For natural gas systems, the gas pressure should not exceed 10-1/2" water column and should not be less than a 7-inch water column. For LPG systems, the pressure should not exceed 14-inch water column or be less than an 11-inch water column. Be sure to check all gas appliances to assure the orifice will operate with the gas supplied.

Connect a properly sized gas supply connector from the gas supply line to the home gas piping inlet. Check that all appliance shutoff valves are open and all appliance burner valves closed. Pressurize the gas piping system by opening the main gas shutoff valve.

Visually check gas appliance vents (i.e. roof jacks) to ensure that they have not been dislodged in transit and are securely connected to the appliance.

ELECTRICAL SYSTEM TEST

CAUTION: ELECTRICAL SYSTEM CONNECTION AND TESTING MUST BE PERFORMED ONLY BY QUALIFIED ELECTRICAL SERVICEMEN USING APPROVED ELECTRICAL TEST EQUIPMENT.

The following should be done before connecting to the power source:

A continuity test with all branch circuit breakers and switches controlling individual outlets in the "on" position should be conducted. There should be no evidence of connection between any of the supply conductors (including neutral) and the grounding circuit. In addition, all noncurrent carrying metal parts of the electrical system as well as fixtures, appliances, and the chassis of the home should be tested for continuity with the grounding circuit. After the home is connected to the electrical service check each receptacle for reverse polarity, open grounds, and shorts.

DRYER INSTALLATION

If this home is equipped with a clothes dryer, it must be exhausted to the outside by a moisture-lint exhaust system.

CAUTION: THIS EXHAUST SYSTEM MUST NOT TERMINATE UNDER THE HOME.

All required components and fittings are provided in the home. Openings in either the wall or floor are provided. After the duct is installed, the openings in the wall or floor (both inside and outside) must be caulked or sealed.

If this home is not equipped with a dryer, but an electrical outlet is provided for one, then an opening in the wall or floor is provided. Installation of the exhaust system must be in accordance with the dryer manufacturer's installation instructions.

FLASHING AND SEALING

Joints between dissimilar materials and joints between exterior coverings and frames of openings shall be protected with a compatible sealant suitable to resist infiltration of air or water, except for any designed ventilation of wall or roof cavity.

When adjoining material or assemblies of materials are of such nature that separation can occur due to expansion, contraction, wind loads or other loads induced by transportation, the sealant must be of a type that is flexible and non hardening to resist these conditions.

BOTTOM BOARD PATCH

Use a bottom board patch to seal openings and to repair tears in the bottom board.

Patching of bottom board:

1. Using 3M double-faced tape #927, patches may be constructed of any shape and size utilizing scrap pieces of bottom board or other suitable material.
2. A 2" reinforced pressure-sensitive, one-sided tape, 3M #393 or equivalent, is available for patching small tears and cuts which occur during set up.
3. Outward flare tacker may be used on site. The patch should first be affixed to the bottom using 3M #393 or equivalent to secure the perimeter and then fastened on the perimeter at 3" intervals with tacker.
4. Per manufacturer's recommendations.

FRAME FINISH TOUCH-UP

The frame of your home has been protected against corrosion at the factory. If for some reason this protection is scraped off, you should touch up the area affected with Mortel #931 — Thin Film Undercoating — water based, or equivalent.

GAS STACKS

In some cases, the roof jack extension for water heater and furnace stacks have been shipped loose, and must be installed before operation of these appliances.

FIREPLACE AND WOOD BURNING STOVES

1. Fireplaces and wood burning stoves must be installed to manufacturer's installation instructions.
2. All "ship loose" components must be installed prior to initial start up of the unit. For example, if the flue stack or chimney and termination pieces are shipped loose in the unit, they must be installed per instruction prior to firing the unit.
3. Use only components supplied by the fireplace or wood burning stoves manufacturer. Use of other components may void your warranty and create a fire hazard.
4. Only use fireplaces or stoves listed for use in manufactured housing.

ROOF GABLE/SOFFIT VENTS

In some cases, roof vents have plastic over them which must be removed. Check for this and remove if found.

PERIMETER VENTING

When installing skirting or perimeter foundation, provide air vents at the rate of one square inch of vent for every square foot of home.

This is effective open area. Please note that insect screens, slats, louvers, etc., used over the open vent area will reduce the effective open area and, therefore, the size of the vent must be increased proportionately. For example, insect screening alone will reduce the effective open vent area 30 - 50% and the vent size must be increased proportionately to compensate. Required venting should be distributed to all walls to promote cross ventilation.

INSTALLATION OF EXTERNAL COOLING UNITS DUCTED INTO MAIN AIR DISTRIBUTION SYSTEM

SINGLEWIDE UNITS:

Air from external cooling units shall be introduced into the main air distribution system such that an equal number of floor registers will result on either side of the entrance point where possible. Where there is an odd number of registers, one side of the entrance point will have an additional register. A damper must be installed at the entrance point of the outside appliance duct to the main distribution duct to prevent back flow of air into the cooling unit when the house internal furnace is functioning. A damper must also be installed at the point where the internal furnace joins the main distribution system to prevent air from flowing into the furnace when the external cooling unit is functioning.

DOUBLEWIDE UNITS:

Air from external cooling units shall be introduced into each half of a doublewide air distribution system such that an equal number of floor registers will result on either side of the entrance point in each half of the home. Where there is an odd number of registers in one or both sides of the home, that side or both sides will have an additional register on one side of the entrance point. A damper must be installed at the entrance point of the outside duct to the main distribution in each half to prevent back flow of air into the cooling unit when the house internal furnace is functioning. Separate ducts from the entrance point under each half of the home will run to a "Y" connection and a single duct will run from this point to the external cooling unit. A damper must be installed at the point where the internal furnace joins the main distribution system to prevent air from flowing into the furnace when the external cooling unit is functioning.

Singlewide and doublewide units:

1. Provisions must be made to prevent simultaneous operation of the internal furnace and the external cooling unit.
2. Structural members (floor joists, etc.) shall not be cut, altered, or removed.
3. Return air openings will be located centrally in the home to draw air evenly from all rooms.

OIL-FIRED FURNACES

When an oil-fired furnace is installed, the oil drain hose must be routed through the floor into a container placed under the home to collect any oil drippings from the furnace. This container should be periodically checked and emptied as necessary. Failure to do this could result in a fire hazard due to collection of oil in the ground below the home.

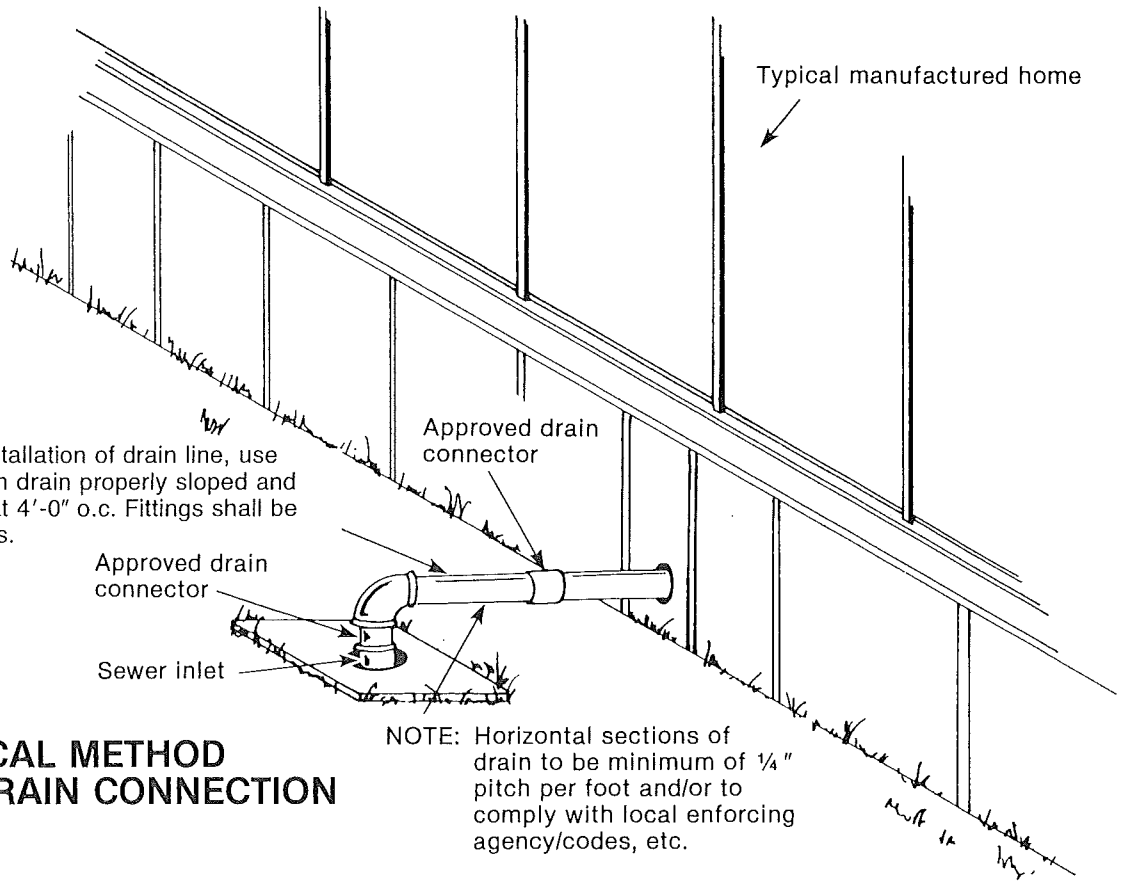

TYPICAL METHOD OF MAIN DRAIN CONNECTION

For field installation of drain line, use 3" min. main drain properly sloped and supported at 4'-0" o.c. Fittings shall be long sweeps.

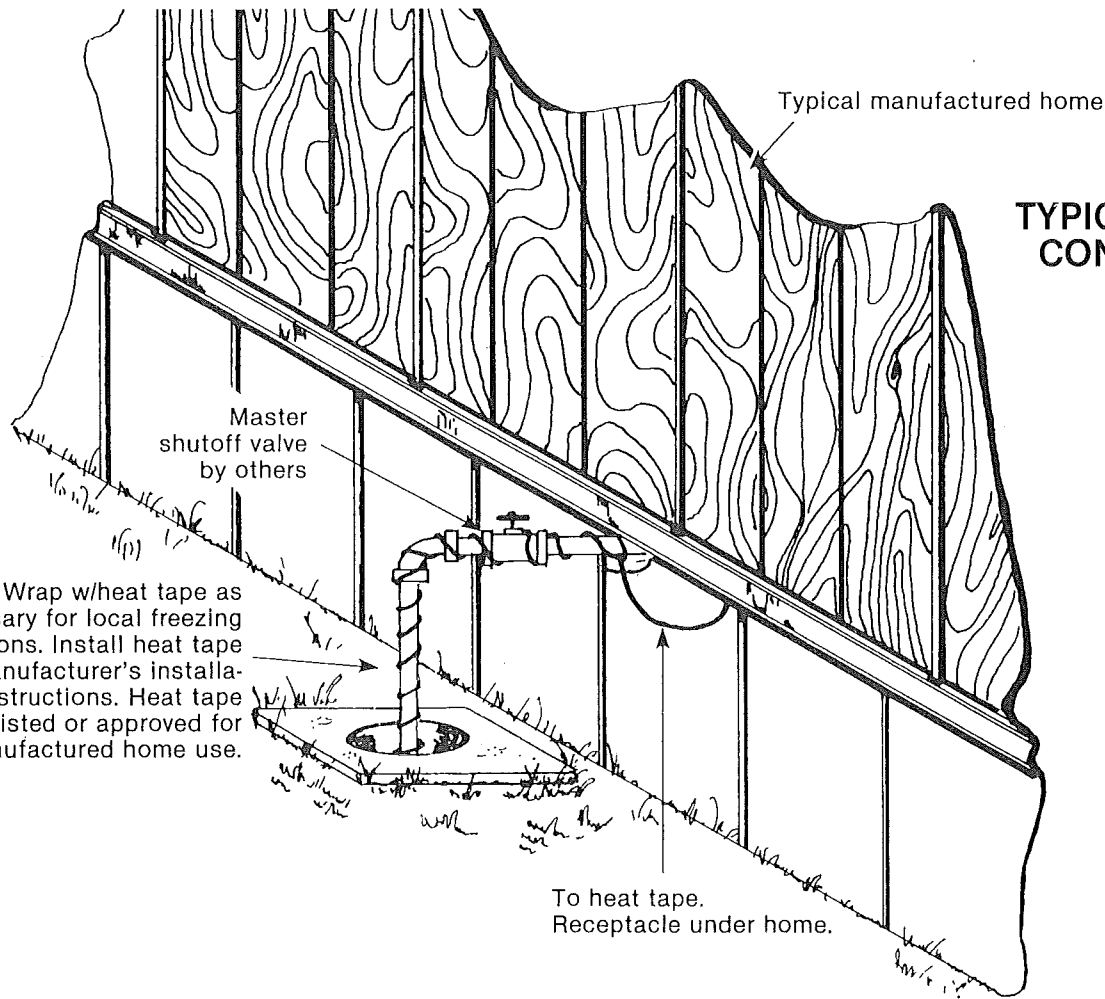

TYPICAL WATER CONNECTION

Wrap w/heat tape as necessary for local freezing conditions. Install heat tape per manufacturer's installation instructions. Heat tape to be listed or approved for manufactured home use.

TYPICAL WATER LINE CROSSOVER

NOTE: If freezing conditions exist, wrap water connector with insulation.
Use water connectors supplied by manufacturer where applicable.

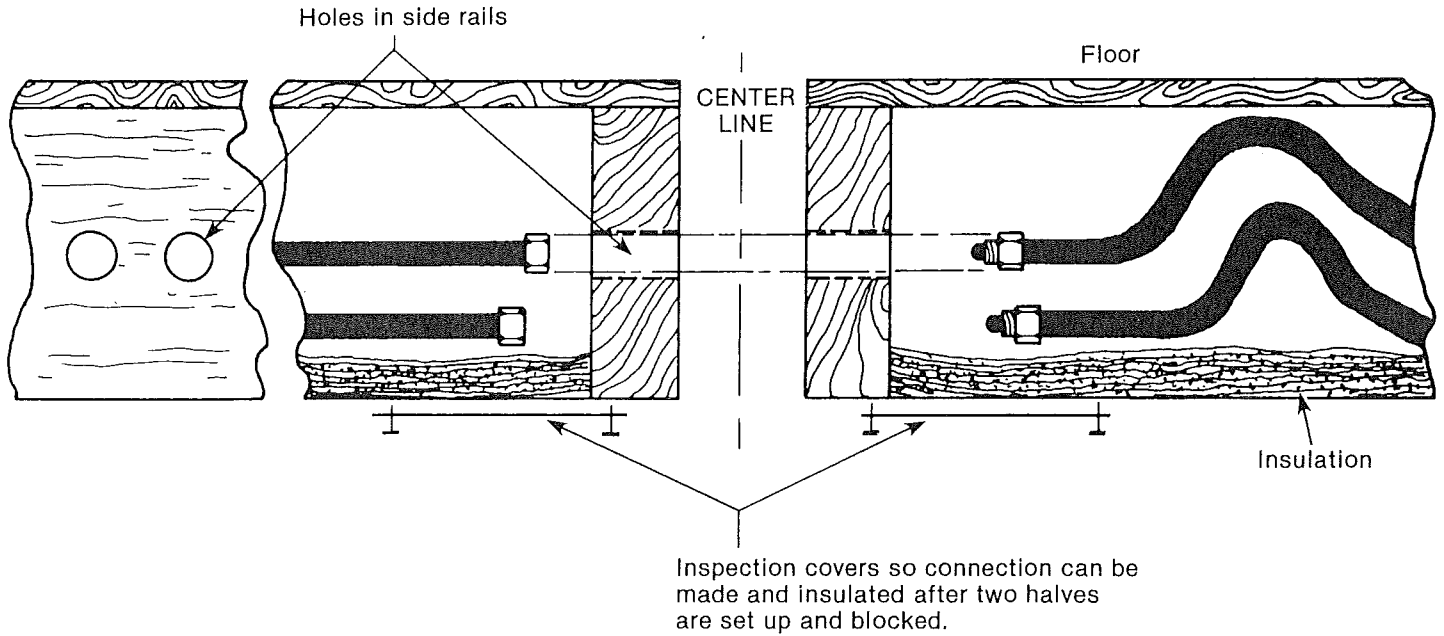

TYPICAL GAS LINE CROSSOVER

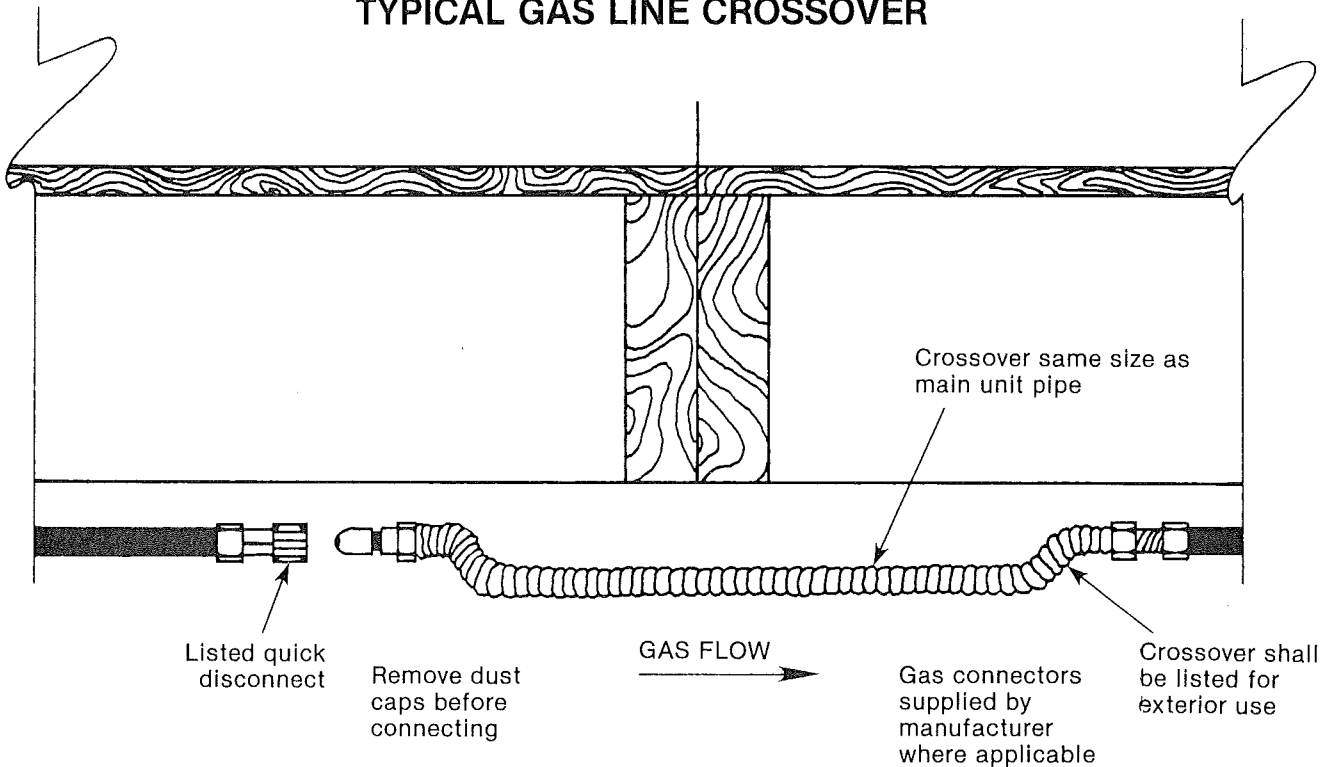

The wires are coiled up under the shipping seal. Before the units are pulled together, place the wires from "B" half into junction box on "A" half. Wires will be color coded and/or tagged to prevent mixing of circuits. Make final connections after units are pulled together.

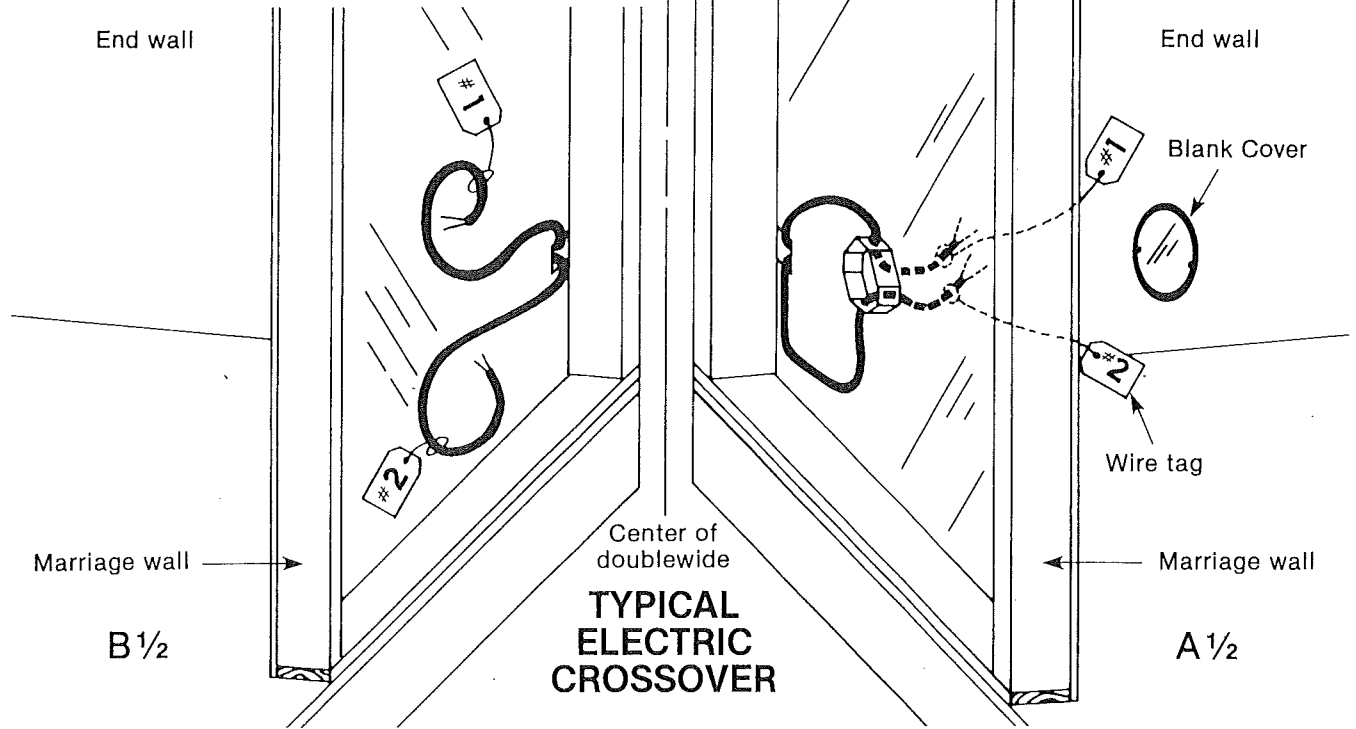

TYPICAL ELECTRIC CROSSOVER

Connect the flex conduit to the junction box on the "A" half. Then make the wire connections using approved wire connectors. Wires will be color coded and/or tagged to prevent mixing of circuits.

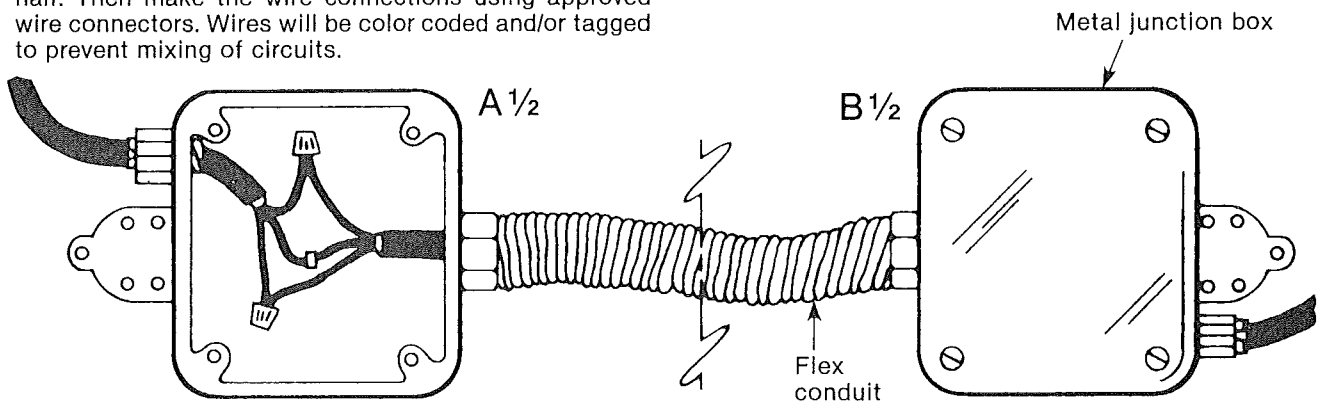

ALTERNATE ELECTRIC CROSSOVERS

This home may be shipped with one or more plug-in connectors. These connectors are to be snapped together on set up. Connectors will be color-coded and/or tagged to prevent mixing of circuits.

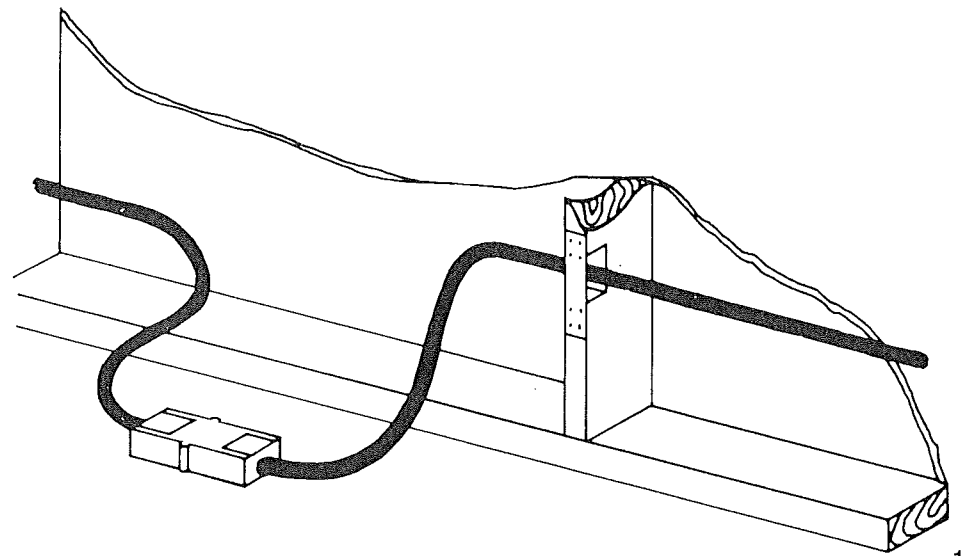

EXTERIOR LIGHT CONNECTION

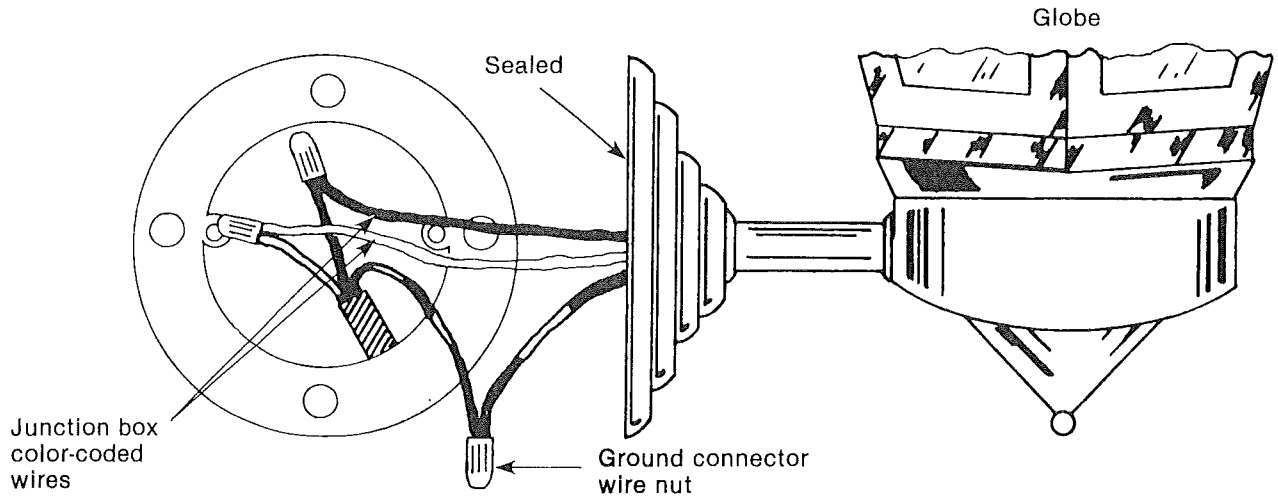

ELECTRICAL CONNECTION EVAPORATIVE COOLER

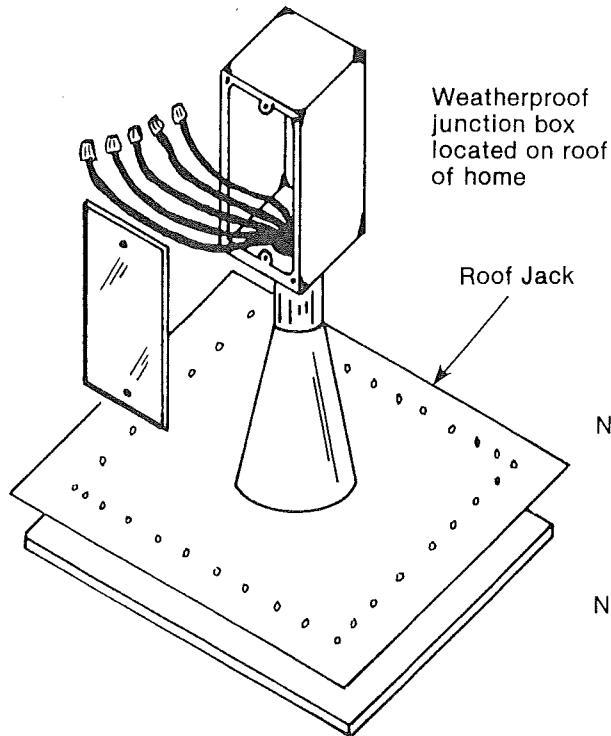

NOTE: Coolers rated at 16 amps to be installed on a 20-amp circuit.

Coolers rated at 12 amps to be installed on a 15-amp circuit.

NOTE: One required for each cooler.

TYPICAL OVERHEAD FEEDER ASSEMBLY

NOTE: Be sure to connect multi-wide chassis together with bonding wire and lug.

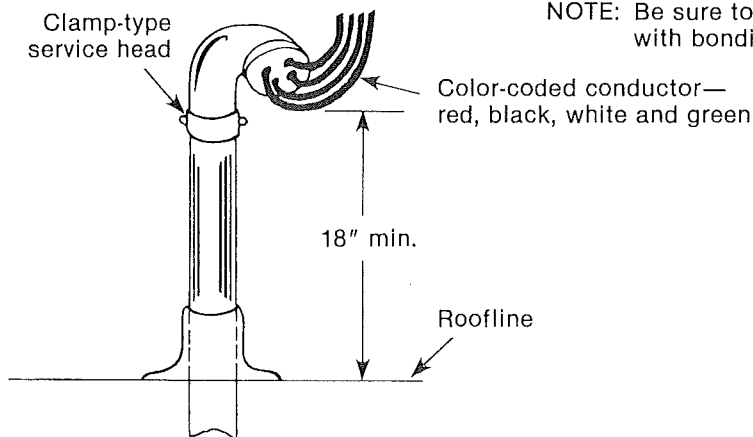

COPPER CONDUCTOR SIZE (75° WIRE)

Service Amps	Wire Size			Conduit Size
	Feeder	Ground	Neutral	
40	#8	#8	#8	3/4"
50	#6	#8	#6	3/4"
60	#6	#8	#6	3/4"
80	#4	#8	#4	1"

COPPER CONDUCTOR SIZE (75° WIRE)

Service Amps	Wire Size			Conduit Size
	Feeder	Ground	Neutral	
100	#3	#8	#3	1 1/4"
125	#1	#6	#3	1 1/2"
150	#0	#6	#3	1 1/2"
200	#000	#6	#3	2"

TYPICAL UNDERSIDE FEEDER ASSEMBLY

NOTE: Be sure to connect Double wide Chassis together with bonding wire and lug.

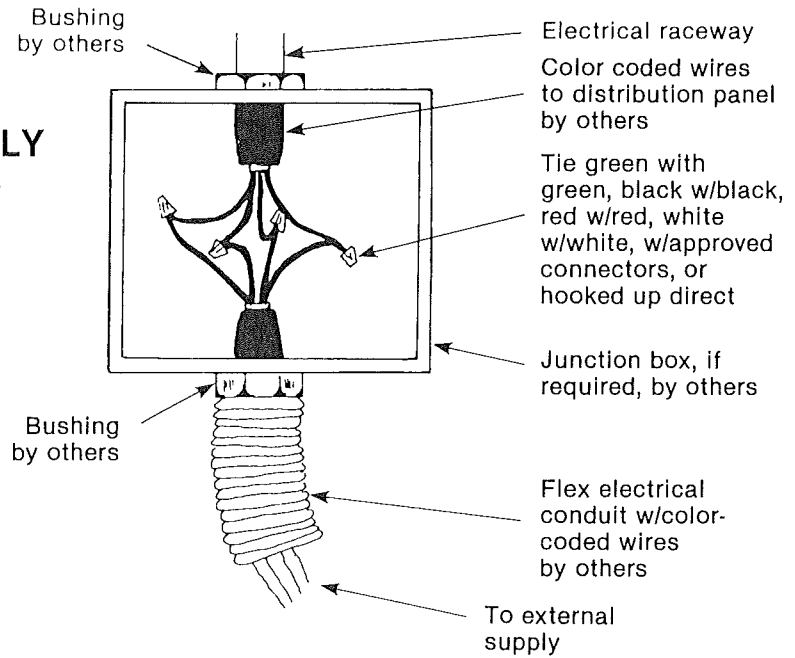

COPPER CONDUCTOR SIZE (75° WIRE)

Service Amps	Wire Size			Conduit Size	Box Size
	Feeder	Ground	Neutral		
40	#8	#8	#8	3/4"	4 x 4 x 4
50	#6	#8	#6	3/4"	4 x 4 x 4
60	#6	#8	#6	3/4"	4 x 4 x 4
80	#4	#8	#4	1"	4 x 4 x 4

COPPER CONDUCTOR SIZE (75° WIRE)

Service Amps	Wire Size			Conduit Size	Box Size
	Feeder	Ground	Neutral		
100	#3	#8	#3	1 1/4"	10 x 10 x 4
125	#1	#6	#3	1 1/2"	10 x 12 x 4
150	#0	#6	#3	1 1/2"	10 x 12 x 4
200	#000	#6	#3	2"	12 x 12 x 4

TYPICAL HEAT DUCT CROSSOVER

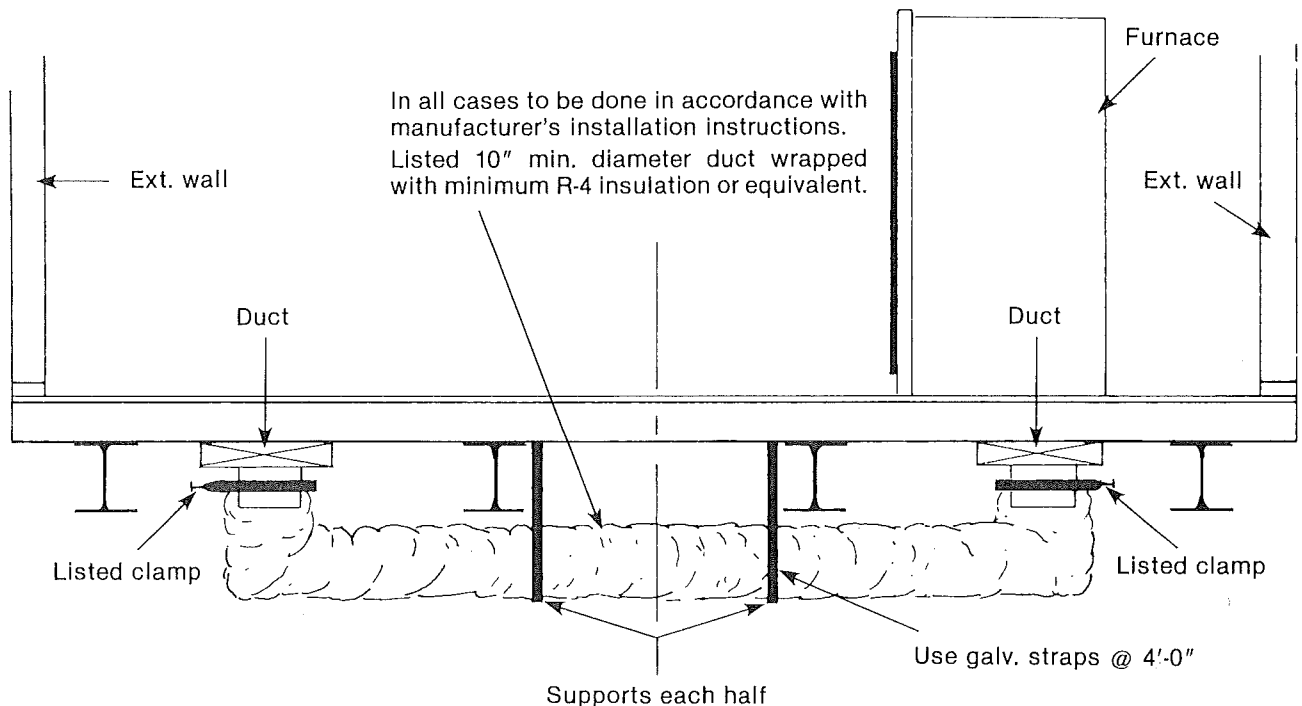

NOTE: Duct shall not come in contact w/ground

DRYER EXHAUST SYSTEM

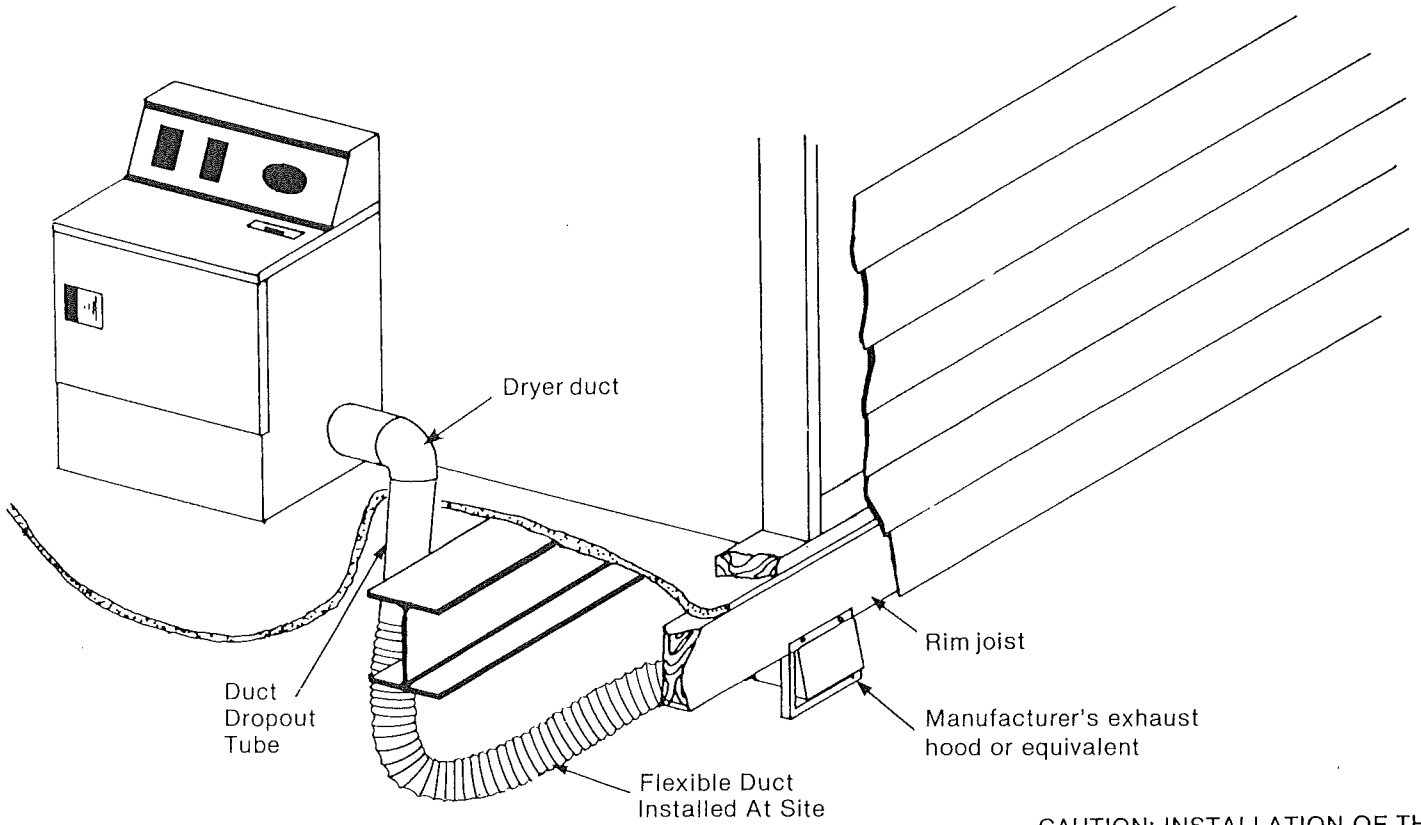

CAUTION: THIS EXHAUST SYSTEM MUST NOT TERMINATE UNDER THE HOME.

CAUTION: INSTALLATION OF THE EXHAUST SYSTEM MUST BE IN ACCORDANCE W/ THE DRYER MANUFACTURER'S INSTRUCTIONS.

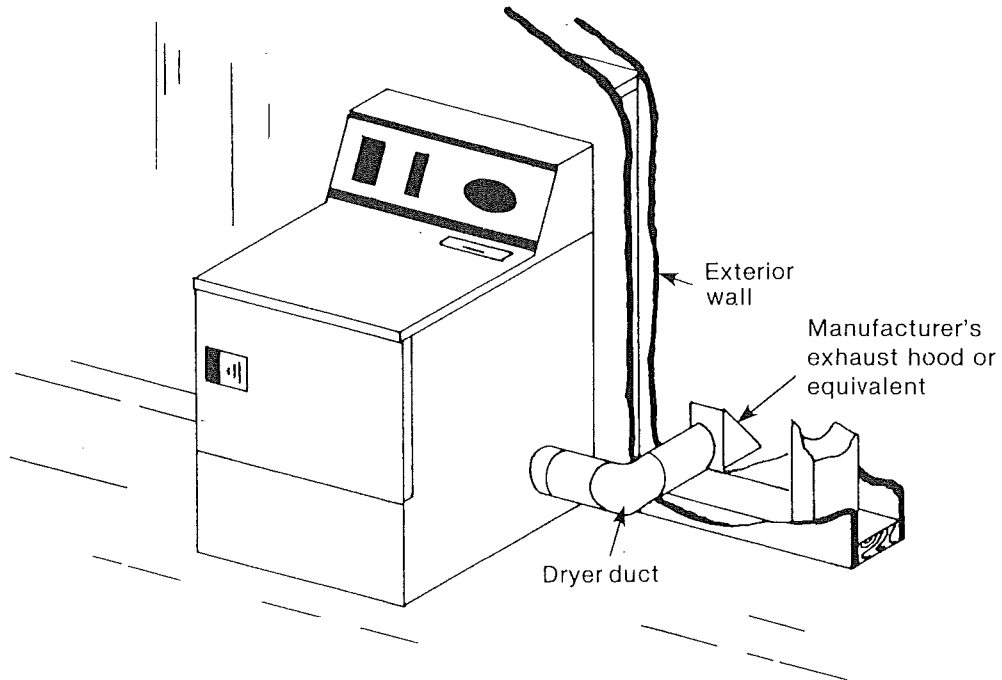

TELEPHONE WIRING FOR DOUBLEWIDE HOMES

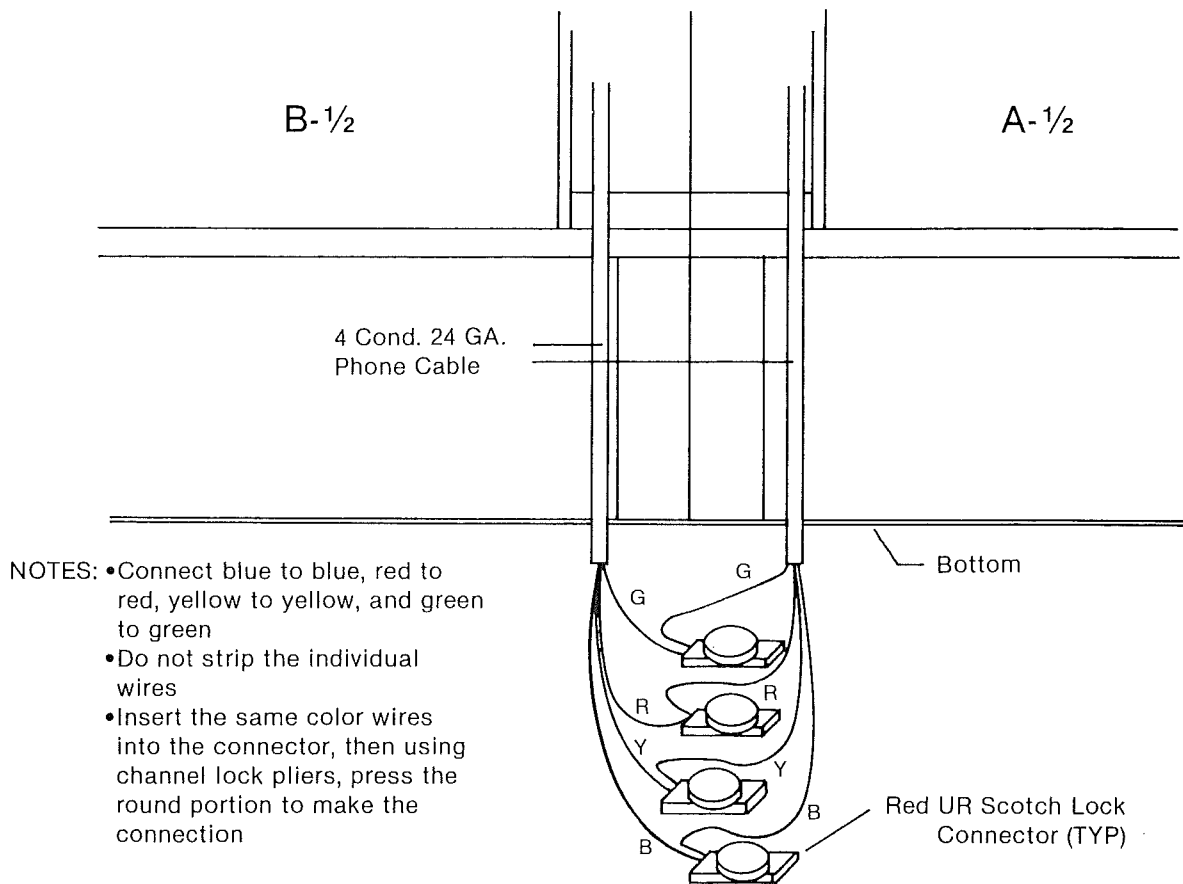

PACO RECOMMENDED JACKING PROCEDURE

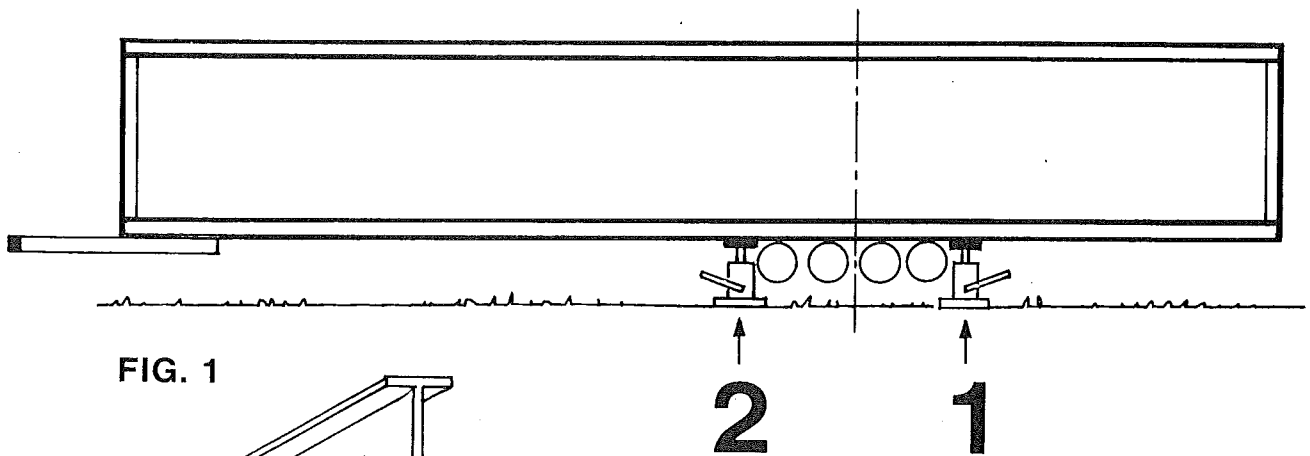
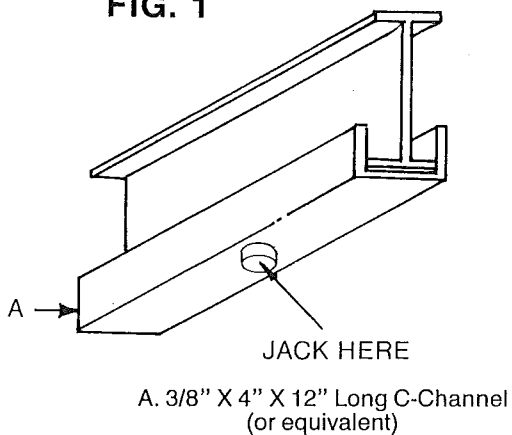

FIG. 1



Use two jacks - one in front of axles and one behind axles. Lifting should be as even as possible, starting with the rear jack first, up a little, then up a little on the front - alternating back and forth until desired height is reached.

Jacking reinforcing plates, or other equivalent means should be used to adequately distribute the concentrated load of the jack head to the frame member to avoid damage to the beam. See Fig. 1.

NOTE: The home set-up information in this Instruction Guide pertains **only** to products manufactured by the 17 plants listed below of Champion Home Builders Co., a subsidiary of Champion Enterprises, Inc. The information in this Guide **does not** apply to homes manufactured by other subsidiaries of Champion Enterprises, such as: Sun Belt Energy Housing, Inc., and Gateway Homes, Inc. (both located at: P.O. Drawer 340; Haleyville, AL 35565; phone: 205-486-9535). For questions pertaining to homes manufactured by Sun Belt and Gateway, please contact them directly.

THESE 17 MANUFACTURED HOUSING PLANTS BUILD VARIOUS HOME BRANDS BY CHAMPION HOME BUILDERS CO.

CALIFORNIA PLANT

Champion Home Builders Co.
P.O. Box 429
Lindsay, California 93247
(209) 562-4951

COLORADO PLANT

Champion Home Builders Co.
P.O. Box 10
Berthoud, Colorado 80513
(303) 532-2632

FLORIDA PLANTS

Champion Home Builders Co.
Route 7, Box 471
Lake City, Florida 32055
(904) 752-4821

Champion Home Builders Co.
Route 7, Box 439
Lake City, Florida 32055
(904) 755-6330

GEORGIA PLANTS

Champion Home Builders Co.
P.O. Box 5
Ellaville, Georgia 31806
(912) 937-2521

Champion Home Builders Co.
P.O. Box 1836
Thomasville, Georgia 31799
(912) 228-0525

IDAHO PLANT

Champion Home Builders Co.
P.O. Box 190
Weiser, Idaho 83672
(208) 549-1410

INDIANA PLANT

Champion Home Builders Co.
P.O. Box 57
Ridgeville, Indiana 47380
(317) 857-2561

NEBRASKA PLANTS

Champion Home Builders Co.
P.O. Box 148
Central City, Nebraska 68826
(308) 946-3021

Champion Home Builders Co.
Route 4, Box 85A
York, Nebraska 68467
(402) 362-4455

NEW YORK PLANT

Champion Home Builders Co.
P.O. Box 56
Sangerfield, New York 13455
(315) 841-4122

NORTH CAROLINA PLANTS

Champion Home Builders Co.
P.O. Box 1148
Lillington, North Carolina 27546
(919) 893-5713

Champion Home Builders Co.
P.O. Box 1389
Lillington, North Carolina 27546
(919) 893-2121

Champion Home Builders Co.
P.O. Box 38
Polkton, North Carolina 28135
(704) 272-7675

PENNSYLVANIA PLANT

Champion Home Builders Co.
P.O. Box 343
Claysburg, Pennsylvania 16625
(814) 239-5121

TENNESSEE PLANT

Champion Home Builders Co.
P.O. Box 100
Henry, Tennessee 38231
(901) 243-2041

TEXAS PLANT

Champion Home Builders Co.
P.O. Box 663
Commerce, Texas 75428
(214) 886-2151



CHAMPION
HOME BUILDERS CO.

Corporate Headquarters
5573 North Street, Dryden, Michigan 48428

